

8 4 7 6 3 5 4 2 3 2 1 1

F
D
E
C
D
C
B
B
A
A

F
D
E
C
D
C
B
B
A
A

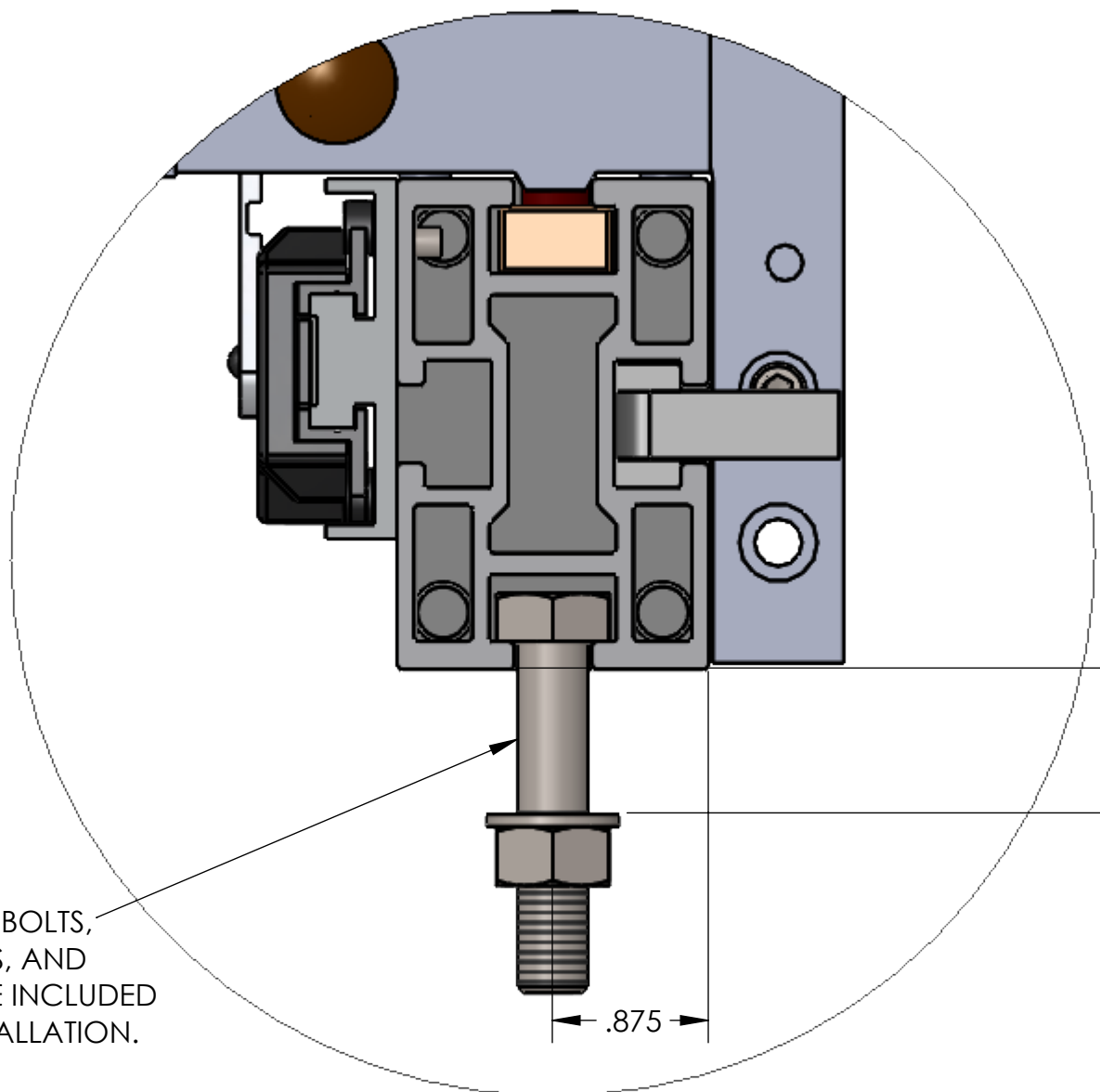

M10 HEX BOLTS, WASHERS, AND NUTS ARE INCLUDED FOR INSTALLATION.

DETAIL A
SCALE 1 : 1

INSTALLATION HARDWARE ACCOMMODATES MOUNTING TO SURFACES UP TO 1.5" THICK

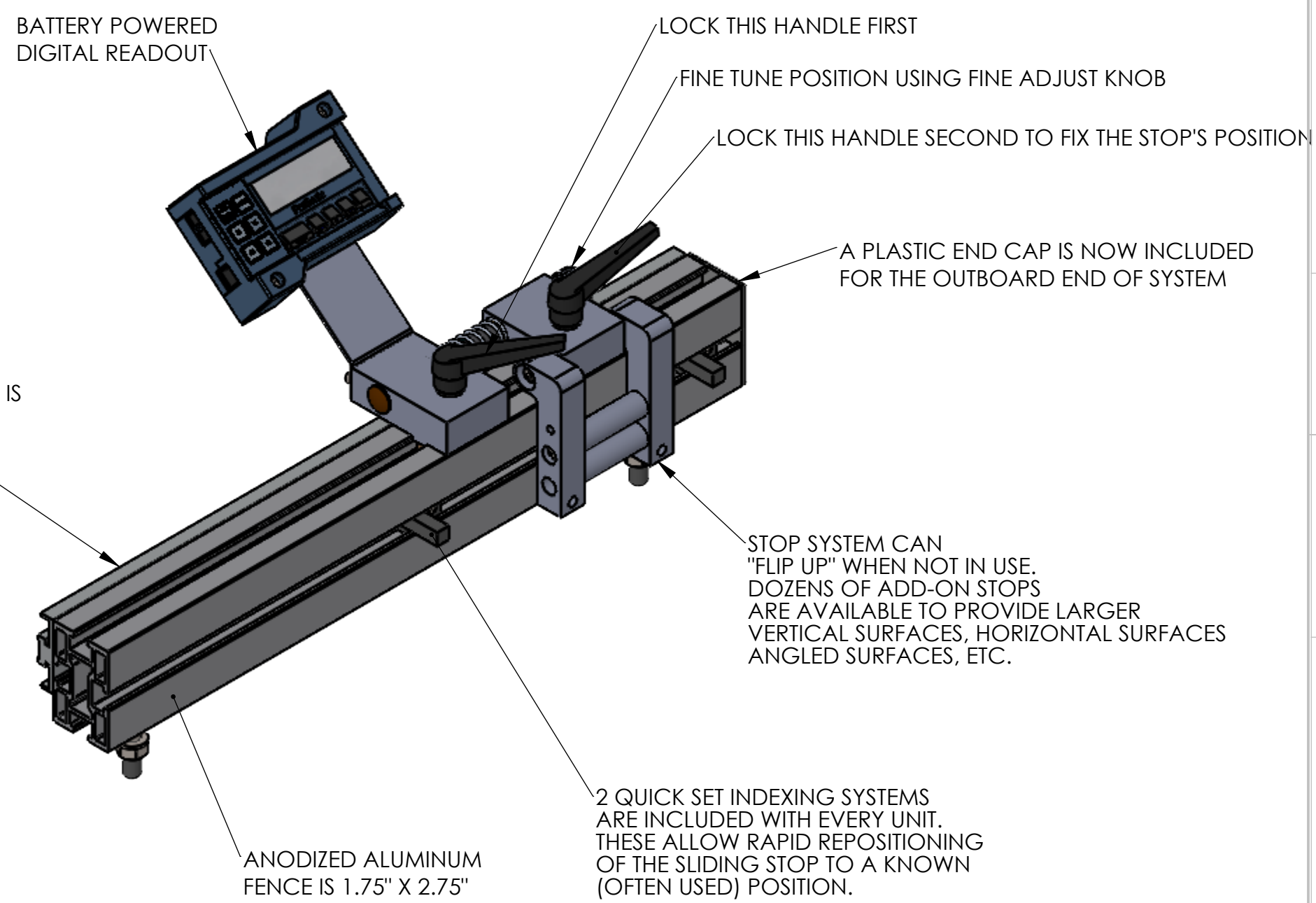

ELECTRONIC SCALE IS MOUNTED TO REAR OF THE FENCE

ANODIZED ALUMINUM FENCE IS 1.75" X 2.75"

2 QUICK SET INDEXING SYSTEMS ARE INCLUDED WITH EVERY UNIT. THESE ALLOW RAPID REPOSITIONING OF THE SLIDING STOP TO A KNOWN (OFTEN USED) POSITION.

STOP SYSTEM CAN "FLIP UP" WHEN NOT IN USE. DOZENS OF ADD-ON STOPS ARE AVAILABLE TO PROVIDE LARGER VERTICAL SURFACES, HORIZONTAL SURFACES ANGLED SURFACES, ETC.

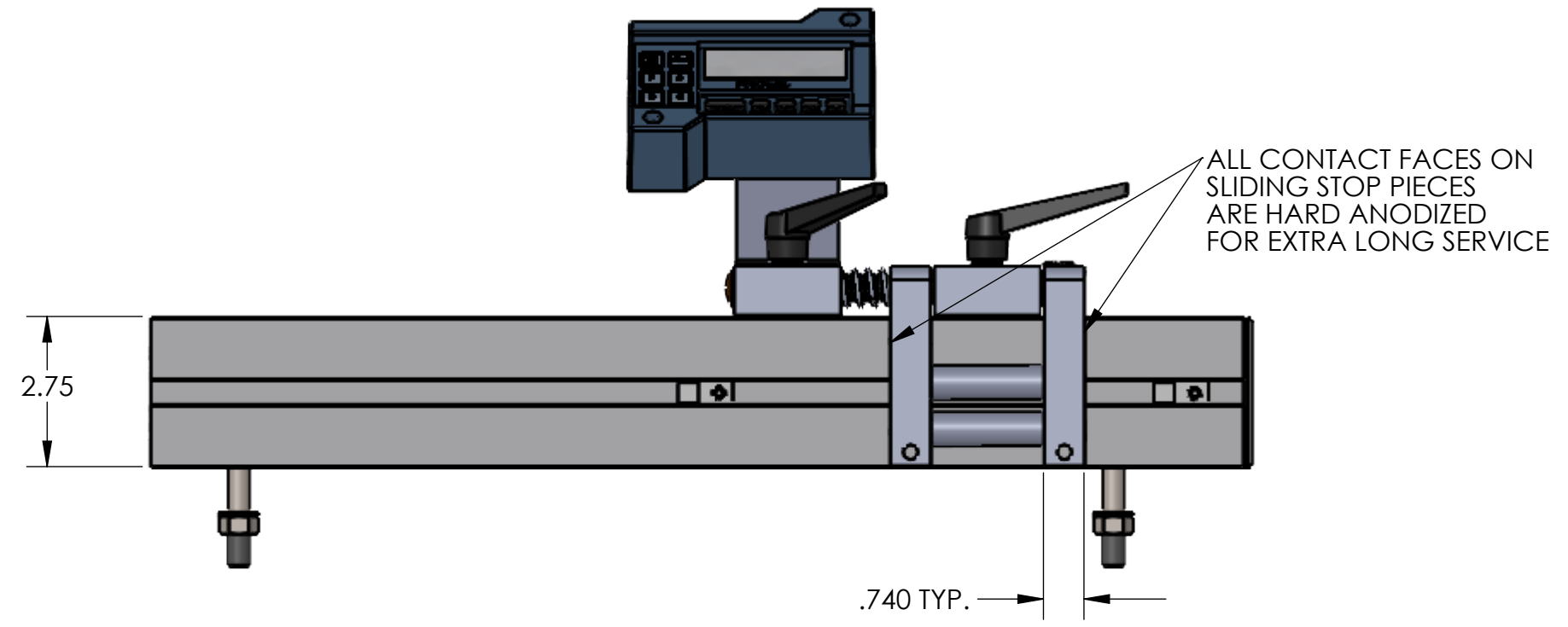
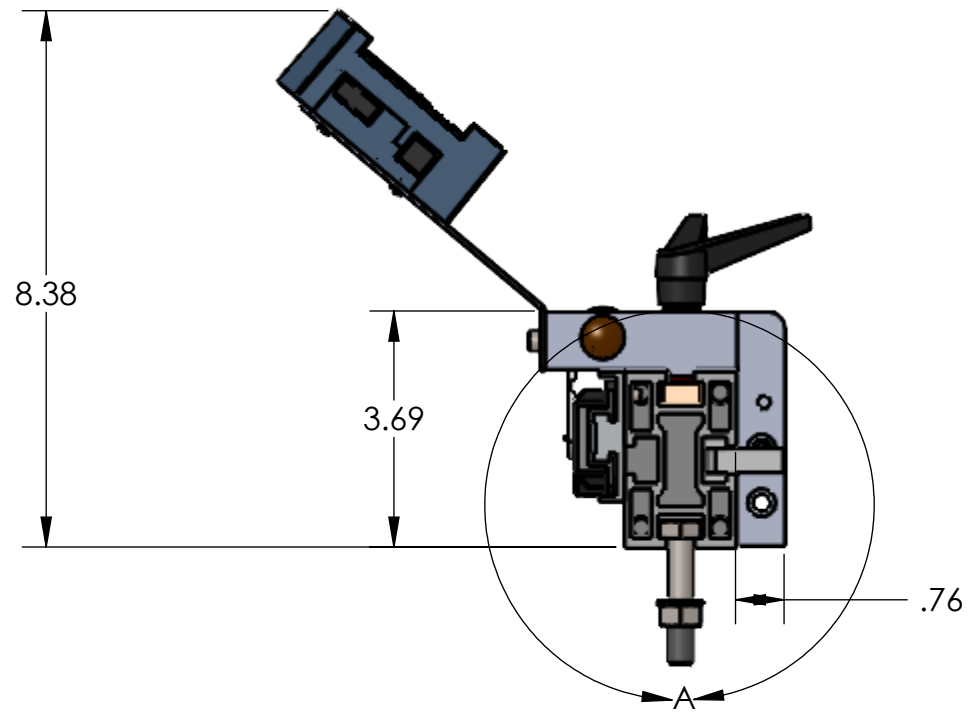

ALL CONTACT FACES ON SLIDING STOP PIECES ARE HARD ANODIZED FOR EXTRA LONG SERVICE

UNLESS OTHERWISE SPECIFIED:		NAME	DATE	ACCURATE TECHNOLOGY INC.	
DIMENSIONS ARE IN INCHES		DRAWN	MF	11-3-21	TITLE: PROSTOP V2 DIMENSIONS
TOLERANCES:		CHECKED			
ANGULAR: MACH ±1 BEND ±2		ENG APPR.			
ONE PLACE DECIMAL ±0.050		MFG APPR.			
TWO PLACE DECIMAL ±0.020		Q.A.			SIZE DWG. NO. REV C ProStop Dimensions A
THREE PLACE DECIMAL ±0.005		COMMENTS:			
INTERPRET GEOMETRIC TOLERANCING PER:				SCALE: 1:3	WEIGHT:
MATERIAL ASST				SHEET 1 OF 1	
FINISH ASST					
DO NOT SCALE DRAWING					

PROPRIETARY AND CONFIDENTIAL
THE INFORMATION CONTAINED IN THIS DRAWING IS THE SOLE PROPERTY OF ACCURATE TECHNOLOGY, INC. ANY REPRODUCTION IN PART OR AS A WHOLE WITHOUT THE WRITTEN PERMISSION OF ACCURATE TECHNOLOGY, INC. IS PROHIBITED.

8 4 7 6 3 5 4 2 3 2 1 1