

DETAIL A
SCALE 1 : 1

PROSCALE GP
READOUT IS
BATTERY POWERED

FINE ADJUST OPERATION.
LOCK HANDLE #1
TURN KNOB CW OR CCW TO ADJUST STOP POSITION.
LOCK HANDLE #2 TO FIX STOP IN PLACE.

ELECTRONIC SCALE

QUICK SETS ARE NOW
MADE FROM STEEL,
OPTIONAL ADD-ONS

MANY ADD-ON PLATES ARE
AVAILABLE TO SUIT DIFFERENT
PRODUCT REQUIREMENTS

ANODIZED ALUMINUM FENCE
IS 1.5 DEEP X 3.0 TALL

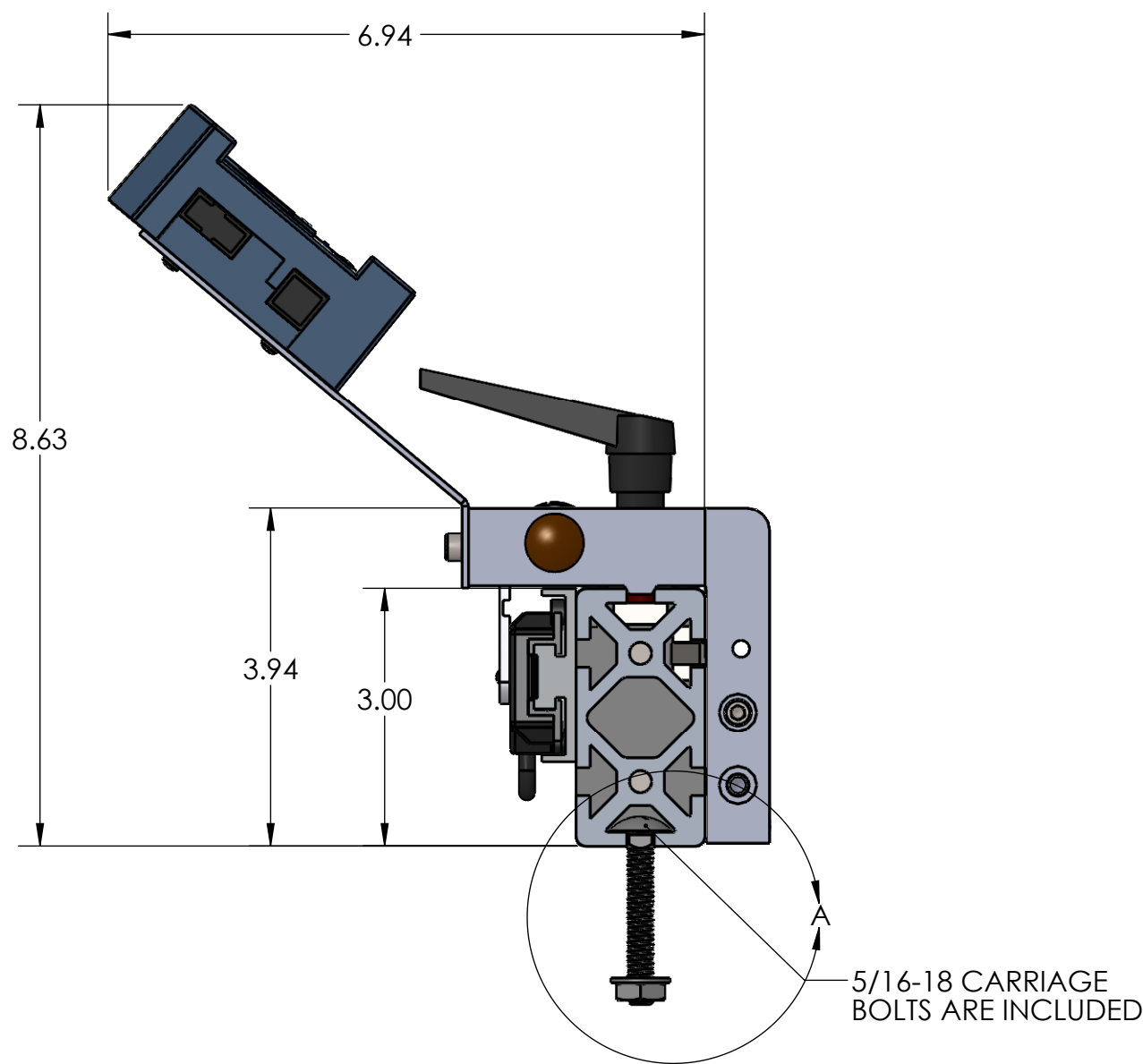

5/16-18 CARRIAGE
BOLTS ARE INCLUDED

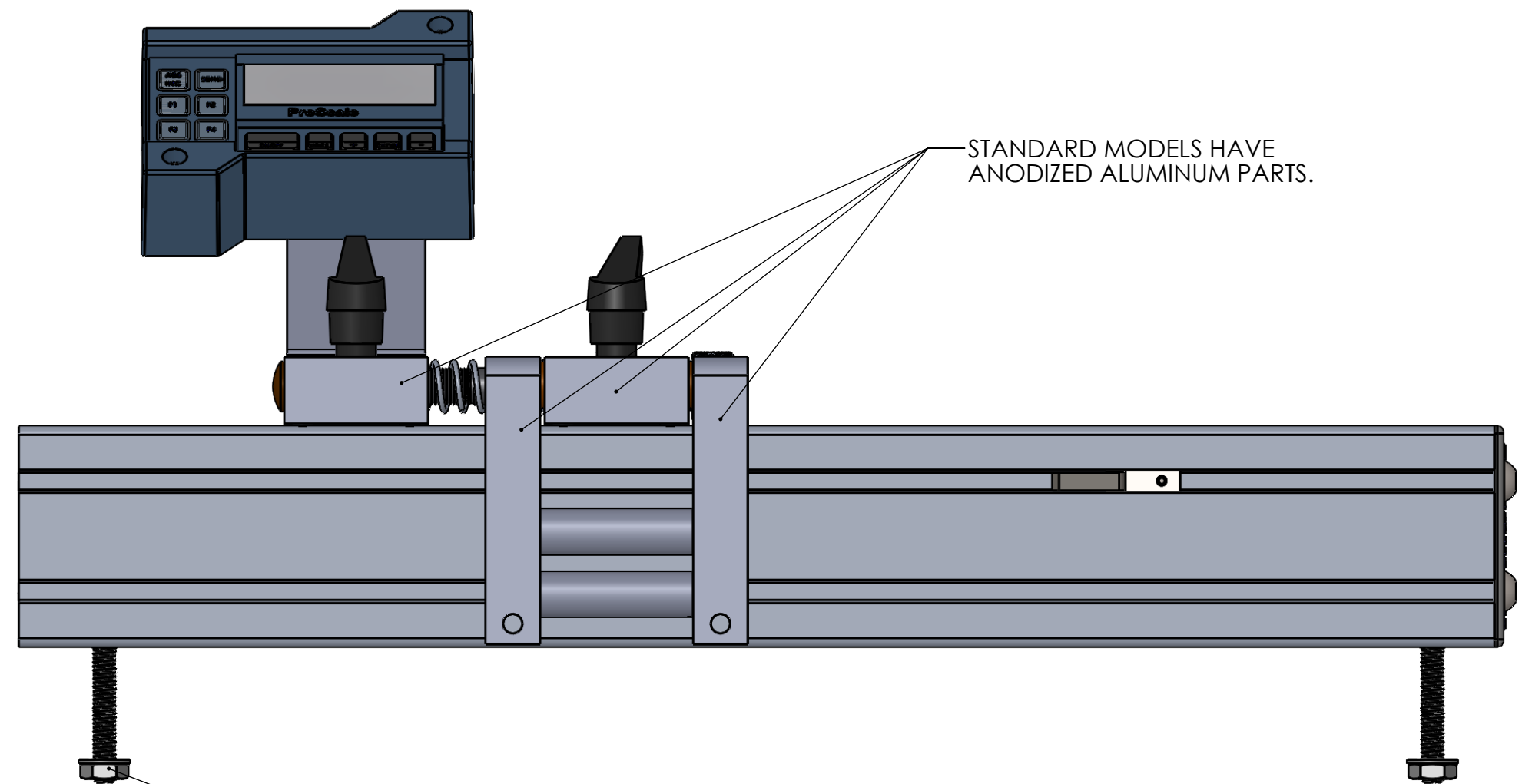

STANDARD MODELS HAVE
ANODIZED ALUMINUM PARTS.

INSTALLATION HARDWARE CAN BE
POSITIONED ANYWHERE ALONG
LENGTH OF PROSTOP. NUTS ARE
TIGHTENED FROM BOTTOM SIDE.

UNLESS OTHERWISE SPECIFIED:		NAME	DATE	ACCURATE TECHNOLOGY INC	
DIMENSIONS ARE IN INCHES		DRAWN	MF	1/30/2022	TITLE:
TOLERANCES:		CHECKED			PROSTOP V3
ANGULAR: MACH ±1 BEND ±2		ENG APPR.			SIZE DWG. NO.
ONE PLACE DECIMAL ±0.050		MFG APPR.			C ProStop 3.0 Assembly
TWO PLACE DECIMAL ±0.020		Q.A.			REV
THREE PLACE DECIMAL ±0.005		COMMENTS:			A
INTERPRET GEOMETRIC TOLERANCING PER:				SCALE: 1:2	WEIGHT:
MATERIAL ASST					SHEET 1 OF 1
FINISH ASST					
DO NOT SCALE DRAWING					

PROPRIETARY AND CONFIDENTIAL
THE INFORMATION CONTAINED IN THIS
DRAWING IS THE SOLE PROPERTY OF
ACCURATE TECHNOLOGY, INC. ANY
REPRODUCTION IN PART OR AS A WHOLE
WITHOUT THE WRITTEN PERMISSION OF
ACCURATE TECHNOLOGY, INC. IS
PROHIBITED.