

Accurate

TECHNOLOGY INC.

Linear Digital Measuring Systems



Basic Readout, #700-1600-251



General Purpose Readout, #700-1600-255
(6 extra keys and more features)



GP Enhanced, #700-1600-256
(firmware version ends with "C", even more features)

This guide applies to ProScale readouts with Firmware Version 5.000 to 5.050C

(The firmware version is displayed on power-up.)

If your readout has a different firmware version, this manual should not be used. Consult factory for assistance.

**PROSCALE
FLUSH MOUNT READOUTS
INSTALLATION & OPERATION**

Readout serial # _____

Date of purchase _____

The following programming parameters have been pre-configured at the factory for this readout.

Parameter Pr2 (Reading Direction) _____

Parameter Pr13 (Linear Multiplier) _____

Parameter Pr14 (Compatibility) _____

If your digital scale has this pattern, set Parameter 14 to 1.



For all other scale patterns, set Parameter Pr14 to 0.

Parameter Pr39 (Non-linear correction) _____

Parameter Pr40 (Non-linear interval) _____

Parameter Pr41 (Temperature compensation) _____

Programming menu access is disabled? _____

SAFETY WARNING

**BEFORE INSTALLATION ON ANY MACHINERY:
TURN OFF MACHINE AND DISCONNECT POWER**

Contents

INTRODUCTION	5
SPECIFICATIONS	6
READOUT FEATURE MATRIX	7
INSTALLATION	8
POWER AND INPUT-OUTPUT CONNECTIONS	9
INITIAL SETUP	10
PRIMARY KEYS ON THE READOUT	11
SUPPLEMENTAL KEYS	12
WHAT DO ALL THE SYMBOLS MEAN?	13
OPERATION & CUSTOMIZABLE FEATURES	15
AUTOMATIC POWER OFF:.....	15
AUTOMATIC POWER ON:	15
AVAILABLE UNITS:	15
RESOLUTION:	15
LOCK:	15
LINEAR SCALING:.....	16
SEGMENT CORRECTION:.....	16
LIMITS:.....	16
ANGLE:.....	16
ABSOLUTE / INCREMENTAL MODES:	17
SEND	17
OFFSET ADDITION	18
OPERATION: ADVANCED FUNCTIONS	19
MONITOR (DRIFT MONITORING)	19
HOLD.....	20
Go/NoGo	21
USING COMPENSATION FEATURES	23
USING AN EXTERNAL INPUT	24
PROGRAMMING MODE (CUSTOMIZING THE READOUT FEATURES)	25
RESETTING ALL PARAMETERS	25
HOW TO ENTER PROGRAMMING MODE	26
HOW TO NAVIGATE AND USE THE PROGRAMMING MODE:.....	26
HOW TO EXIT PROGRAMMING MODE	26
PROGRAMMING PARAMETERS DETAILS.....	27
NON-LINEAR COMPENSATION	34
PREPARING FOR NON-LINEAR COMPENSATION	34
PERFORMING THE NON-LINEAR COMPENSATION PROCESS	35

NOTES ABOUT THE CALIBRATION PROCESS.....	36
OPERATING IN COMPENSATED MODE	36
ENABLING TEMPERATURE COMPENSATION.....	37
LOCKING OUT ACCESS TO THE PROGRAMMING MENU.....	38
ACCESSORIES	40
POPULAR PROSCALE PRODUCTS.....	41

Introduction

This manual includes operation and uses information for installation and customization of ProScale flush mount readouts that have firmware version 5.000 to 5.050. (The firmware version is displayed when the readout is powered on using the ON/OFF key.)

These readout models may be supplied as part of ProScale linear encoder system, as a free-standing readout for use with any Digimatic compatible products, or as part of a turn-key measuring gage built and supplied by Accurate Technology, Inc.

Videos showing many features of these readouts are available at www.proscale.com – be sure to search by your readout's Part Number to see features that are available for each model. (If your readout has a QR label, you can scan the label to go directly to the correct web page.)

The readouts covered in this Manual are compatible with electronic scales that have the following colors and patterns:



This black 'stripes' pattern is used on ProScale Models 190, 290, 390 & 590 systems **Inductive Series II** measuring systems.
For this scale pattern, programming parameter Pr14 should be set to 0.



This green 'zig-zag' pattern is used on ProScale Models 150B, 250B, 950, 150G, and 250G **Absolute Series** measuring systems made 1996 to 2022.
For this scale pattern, programming parameter Pr14 should be set to 1.



This blue 'stripes' pattern was used on ProScale Models 180, 280, 380 & 580 systems **Inductive Series I** measuring systems – made 2007 to 2012.
For this scale pattern, programming parameter Pr14 should be set to 0.



This green 'stripes' pattern was used on ProScale Models 100, 200 systems – made 1989 to 2010. **These readouts have limited compatibility with this scale type; they are not recommended for long term use.**

Note: This manual is not meant to be 100% comprehensive. There are too many possible uses for these products to address every possible application. Further, the development of these readouts is forever ongoing, and features are being added all the time.

Specifications

Display Range: Inches: ± 999.999 inches
Millimeters: ± 9999.99 mm
Centimeters: ± 999.999 cm
Fractions: $\pm 399 \frac{63}{64}$ inches

Resolution: Inches: 1, 2, 3, or 4 decimal places
Millimeters: 1 or 2 decimal places
Centimeters: 1, 2, or 3 decimal places
Fractions: $\frac{1}{16}^{\text{ths}}$, $\frac{1}{32}^{\text{nds}}$, or $\frac{1}{64}^{\text{ths}}$

Operating Power: 1 CR123 Battery, or 12-24 Volts DC

NOTE: If both external and battery sources are connected, the readout will automatically use the external power source when available.
External power requires a male terminal plug #200-1016-001.

Operating Temperature: 32 to 120°F (0 to 50°C)

Inputs: ProScale encoders only

All models include a female terminal strip connection that allows a footswitch or pushbutton control for keypad emulation.*
Requires male terminal plug #200-1016-001.

Outputs:

SPC Port that is compatible with most Digimatic type collectors, printers, converters. *Note: The Basic readout's port only works with devices that remotely request information or when an external footswitch or pushbutton are connected.*

All models also have a terminal strip connection that provides output ALERTS for Monitor mode, Limits mode, or Go-NoGo mode.*
Requires male terminal plug #200-1016-001.

* The terminal strip can only be used for input or output features; both cannot be used at the same time.

NOTE: ProScale is intended for indoor use only.

Readout Feature Matrix

	Basic	General	Enhanced
Battery Operation	Yes	Yes	Yes
External power operation	Yes, for most setups	Yes, for most setups	Yes, for most setups
Absolute and incremental modes	No	Yes	Yes
Programmable Datum key	Yes	Yes	Yes
Selectable resolution	Yes	Yes	Yes
Selectable units	Yes	Yes	Yes
Auto on	Yes	Yes	Yes
Auto off	Yes	Yes	Yes
Programmable Offsets	No	Yes	Yes
Programmable limits	Yes	Yes	Yes
Programmable Go, NoGo values	No	Yes	Yes
Position Monitor	No	Yes	Yes
Linear Scaling	Yes	Yes	Yes
Non-linear compensation	No	No	Yes
Temperature compensation	No	No	Yes
Programming lockout	Yes	Yes	Yes
Compatible with wireless transmitters	No	Yes	Yes

Installation

These readouts may be mounted several ways:

1. Using Velcro or double-sided tape
2. Use the 3 punch-out holes inside case.
Mount readout to machine/panel using #6 or M4 flathead screws.

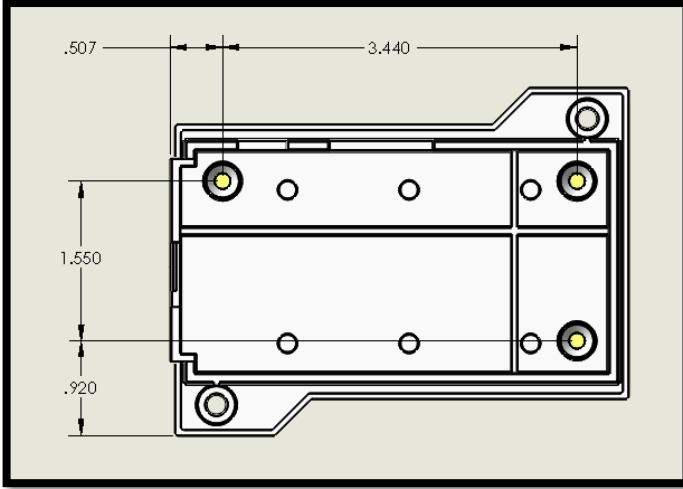

3. Use any (or all) of the six holes on the back of the readout.
Mount using #4 sheet metal or M2 screws.

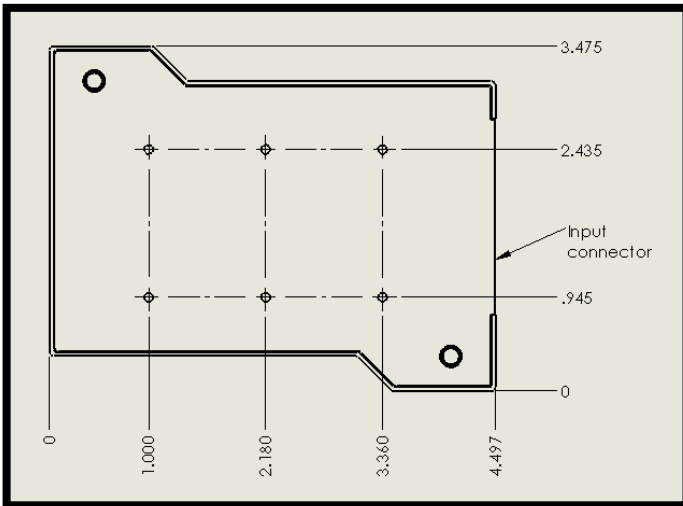

Power and Input-Output Connections

These readouts are powered by a single CR123 lithium battery. Unless specially ordered, the readout will deliver to you with a battery installed.

A battery indicator will appear on the left side of the LCD screen. There are 3 tiers of battery shown, which represent the voltage level of the battery. The typical battery life for these readouts is 8-9 months.

Battery life depends on how often the readout is being used, and which programming options are enabled. The screen will show **LO BAT** when a new battery is required for reliable operation.



Battery Replacement:

Remove the 2 screws in the upper right and lower left corners of the readout. Lift the cover off. Remove the old battery and install a new battery, noting the proper orientation. Replace the cover and screws.

External Power:

These readouts also support use of external power if:

1. The scale type is any model **except** Model 150B or Model 250B type. (Consult factory for assistance if scale type is not known.)
2. The input power is 12 – 24 volts DC. (AC power sources are not supported.)
3. The 3-position male terminal plug for the readout has been supplied.
4. Common for the machine and the readout must be the same. A “hot chassis” condition may permanently damage some or all of the electronics (such damage is not covered by warranty).

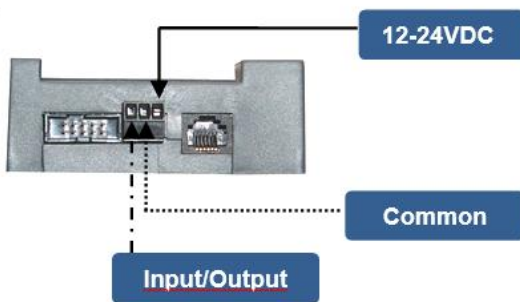

If external power is used, but a power loss occurs, the readout will automatically switch to battery power (if a battery is installed). The readout will automatically switch back to external power when it is restored.

NOTE: Upon initial power-up with an external power connection, the readout will ‘search’ for a battery and report **NO BAT** if a good battery is not found.

Initial Setup

Follow these steps to configure your readout for initial use:

1. When the readout is first powered on, it may show a **No Enc** message. This means there is not an encoder connected to the readout. To clear the message, connect a compatible encoder.
Note: Encoder must be installed onto a scale FIRST.
2. When an encoder is first connected, the readout may show **No Pos**. This informs the user that a position has not been programmed yet. For the initial setup, use the DATUM, and PLUS keys to set a **POSITIVE** starting value. (Any POSITIVE value will work for now.)
3. Choose the units that will be initially used (millimeters, inches, or fractions). Each press of the UNITS key will change the units that are displayed. (The screen will show the units description each time the UNITS key is pressed.)
4. Check the reading direction:
 - a) With the readout showing a POSITIVE number on the screen, move the encoder system a short distance.
 - b) Take note if the displayed value increased or decreased.
 - c) If the displayed value got larger/smaller, and this **IS** correct for your installation, no further steps are needed.
 - d) If the displayed value got larger/smaller, and this **IS NOT** correct for your installation, the reading direction needs to be reversed. This can be accomplished two ways:
 - i. If your encoder system is a Model 19, 29, 190, 290, 390, or 590 type, you can rotate the encoder 180 degrees on the scale.
 - ii. If the encoder cannot be rotated, or if the encoder is a Model 150 or Model 250 system, the reading direction must be reversed using the programming mode, parameter Pr2. See pages 26-27 for making programming changes.
5. Calibrate the readout. Since there are many thousands of applications for ProScale systems, all calibration methods cannot be described here. However, the general steps are the same:
 - a. Determine what value the readout should be showing.
 - b. Use the DATUM, PLUS, and MINUS keys to adjust the reading on the screen to match desired value. NOTE: To rapidly adjust the value, press and hold the PLUS or MINUS key down. (The update speed will progressively increase the longer the key is held down.)

Primary keys on the readout

All the primary keys on the keypad have multiple functions.



What happens on a **QUICK PRESS** of each key?

Key	Action
ON/OFF	The readout turns on or off.
UNITS	The units change. <i>Note: Available units can be restricted with custom programming settings.</i>
PLUS	The displayed value is increased one unit.
DATUM	The displayed value is set to the pre-programmed datum value. <i>Note: This value is zero by default, but it can be custom programmed to be any value.</i>
MINUS	The displayed value is decreased one unit.

What happens if a **KEY IS HELD DOWN**?

Key	Action
ON/OFF	Nothing
UNITS	Nothing
PLUS	The displayed value progressively increases.
DATUM	After 4 seconds, the battery voltage is displayed. After 6 seconds, the system voltage is displayed. After 8 seconds, the readout's temperature is displayed.
MINUS	The displayed value progressively decreases.

Key **COMBINATIONS**:

For these actions, **press and hold the first key**, then **quickly press and release** the second key. (*This action is the same as making a capital letter on a computer; the first key acts like SHIFT.*)

Press and hold	Then quickly press and release	Action
ON/OFF	UNITS	LOCK (or unlock) the keypad.
UNITS	DATUM	Enters or exits the programming mode.
UNITS	PLUS	Adds one segment to displayed value. (<i>Models 150/250 only.</i>)
UNITS	MINUS	Subtracts one segment to displayed value. (<i>Models 150/250 only.</i>)

[Note: Additional key combinations exist, and more detail is provided later in this manual, where applicable.](#)

Supplemental keys

Some readout models have a supplemental keypad that allows additional features to be used. See below for functions of these keys:





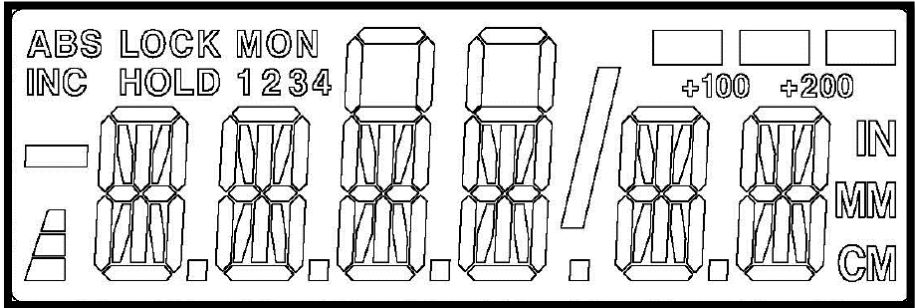

Key	Quick press action	Press and hold action
ABS/INC	When in ABS mode, no action. When in INC mode, the INC value is reset and KERF is displayed. (See page 17 for more details.)	When in ABS mode, toggles readout to INC mode (screen shows INC MD for a moment). When in INC mode, toggles readout back to ABS mode (screen shows ABS MD for a moment).
SEND	The currently displayed value is sent to the SPC port (screen shows SEND for a moment).	<i>None</i>
F1	An offset value is applied. (<i>OFF x is displayed for a moment</i>). Also used to store compensation point data during non-linear programming process.	<i>None</i>
F2	Used to set compensation end point during non-linear programming process.	<i>None</i>
F3	Turns Monitor mode on or off. (<i>If monitor feature is enabled in the programming menu.</i>) Also starts editor for Go/NoGo editor. (<i>If Go/NoGo feature is enabled.</i>)	<i>None</i>
F4	Turns HOLD mode on or off. (<i>If hold feature is enabled in the programming menu.</i>) Also edits values in Go/NoGo editor. (<i>If Go/NoGo feature is enabled.</i>)	<i>None</i>

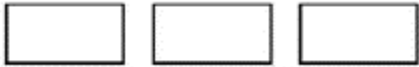
What do all the Symbols mean?



Symbol	Meaning
ABS	The digital readout is operating in Absolute measurement mode.
INC	The digital readout is operating in Incremental (temporary) mode. Press and hold ABS/INC key 3 seconds to go back to ABS mode.
LOCK	The readout is in LOCK mode. This prevents loss of calibration if PLUS, MINUS, or DATUM keys are pressed. See page 11 for key combination to turn this off.
HOLD	The readout's display is frozen. When this feature is enabled, press F4 key to turn on/off.
MON	Monitor mode (drift alarm) is turned on. When this feature is enabled, press F3 key to turn on/off.
1 2 3 4	When any of these are displayed, the readout is adding a programmed offset value to the primary dimension. Offsets are useful for applications with multiple fixed data points.
	These are used with 16 th and 32 nd fractional inch modes. Each bar represents an extra 1/64 th long/heavy on the dimension.

Symbols (continued):

	When using fractions over 99 inches, one (or both) of these will light to show a value over 100 inches. For example: measurement is 205 5/16. The readout will show 5 5/16 and turn on the +200 indicator.
	Minus sign. Turns on when a negative value is displayed.
	Battery level indicator. When all 3 bars are lit, your battery is good. When only bottom bar is lit, a new battery is needed soon.
	Vinculum – used in fractions mode to separate numerator from denominator.
	Units indicator. IN for decimal or fractional INCHES MM for millimeters. CM for centimeters. (Press UNITS key to change.)

Operation & Customizable Features

All of the keys on the readout have multiple functions and some also have key combinations for extra controls. See pages 11-12 for more information about how the keys work separately and in combination.

Some customization and operation features require changing parameters in the programming menu. See pages 26-32 for more information about using the programming menu.

Automatic power off: To prolong battery life, the readout has a built-in timer that turns off the LCD screen after 15 minutes of inactivity. If you wish to shorten or extend this timer, use the programming menu to change parameter Pr12 (see pages 26-28).

Automatic power on: If the LCD is off, and there is motion greater than 0.10mm (.004 inches), the screen will wake up automatically. If you wish to increase the amount of motion required, use the programming menu to change parameter Pr5 (see pages 26-27).

Available units: By default, the readout will display measurements in millimeters, decimal inches, fractional inches (16th, 32^{nds}, and 64^{ths}). If you wish to restrict the units available for display, use the programming menu to change parameter Pr11 (see pages 26-27).

Resolution: By default, the readout displays millimeters to 2 decimal places, and decimal inches to 3 places. If you wish to change the resolution of the displayed measurements, use the programming menu to change parameter Pr4 (see pages 26-27).

NOTE: The display will auto-range when needed. For example, if you configure the readout to show 4 decimal places in inches, but the measurement exceeds 99.9999 inches, the LCD screen does not have enough characters to show all digits. The readout will automatically reduce the decimal places to 3 when this happens.

LOCK: A user can “lock-out” the position adjustment keys (**PLUS, datum & MINUS**) to prevent accidental changes of the displayed value. See page 11 for the proper key combination. The word **LOCK** will display in the upper left corner of the LCD.

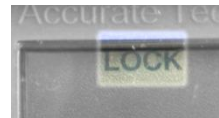

To deactivate this Key Lock, use the same key combination.

NOTE: Key Lock can also be enabled using the programming menu, parameter Pr3 (see pages 26-27).

In some cases, changing both parameter Pr3 to 0, AND the key combination may be required to unlock the readout.

Linear Scaling: In some installations, it may be desirable to apply a linear adjustment. For instance, you may want to fine-tune the system using a small adjustment value like 0.99999. Or you may want the readout to display double the actual motion made by the encoder using a value like 2.00000. Parameters Pr13 and Pr16 can both be used for this purpose. See pages 26-28 to change these, and pages 23 for more information on when to use each of these settings.

Segment Correction: When using ABSOLUTE SERIES type scales, the maximum slew rate (how fast encoder can be moved) is typically 10 inches per second (depends on the encoder type and which features of the readout are turned on). If the encoder is moved too quickly, the readout can lose its count of scale "segments". When this happens, the displayed value will be incorrect by 430mm (either too large or too small, based on the direction of travel). If this happens, the displayed value can be quickly corrected:

- To **add** one segment to the displayed value:
Press and Hold UNITS key and then Momentarily press the + key. The display will increase by 430.08mm (16.933 inches).
- To **subtract** one segment from the displayed value:
Press and Hold UNITS key and then Momentarily press the – key. The display will decrease by 430.08mm (16.933 inches).

Note: Segment correction only works when programming parameter Pr14 is configured to 1.

Limits: The readout can be programmed to alert the user when an upper or lower limit is reached. To enable this feature, use the programming menu to change parameter Pr27 to a value of 1 (see pages 26-30). Program the lower limit value in parameter Pr28. Program the upper limit value in parameter Pr29. During normal operation (between the limit values), the LCD will show the current measurement. When the displayed position moves outside the limits, the readout will alternate the position with either **HI LMT** or **LO LMT** on the screen.

The readout can also output a signal when limits are exceeded. This requires a male terminal strip be added to the readout and wired to common and I/O pin, as shown on page 9. (The output signal is set to NO or NC by parameter Pr37.)

Angle: The readout can be configured to compute and display angular measurements over a limited range (85 to 95 degrees). A ProScale linear encoder is the only input supported for this.

Absolute / Incremental modes:

(Not available on the Basic readout)

The readout has two measurement indexes. One is called ABS (absolute) and the other INC (incremental). The ABS measurement is the reference distance to a fixed or known position. The INC measurement is a **temporary** point-to-point distance used only to make incremental/relative movements from one position to another. These modes are analogous to the odometer and tripmeter in your car.

The readout automatically enters ABS mode when power is first applied. This is indicated by **ABS** shown in the upper left corner of the LCD. To enter INC (Incremental) mode, *press and hold* the **ABS/INC** key for 3-4 seconds. The **ABS** indicator will turn off and the **INC** indicator will turn on.

When INC mode is initially entered, the displayed position will change to reflect a new reference point at the current position of the encoder. This is typically a position of zero but may be changed by using the **+** or **-** keys to enter an offset. Moving the encoder in either direction will display the distance moved from the initial INC starting point (plus any offset). To complete another incremental measurement from the new position, *quickly press and release* the **ABS/INC** key. The readout will again change to zero (or the previously programmed offset).

To return to the ABS mode, *press and hold* the **ABS/INC** key for 3-4 seconds.

NOTES:

1. If you frequently use the INC mode, you can change the timing for the ABS/INC key press. Set programming parameter Pr22 to a 1.
2. The INC mode is meant to be temporary. **This key should never be used to set a gage's absolute zero point.**

Send

(Not available on the Basic readout)

The readout has an output port that can be used to send measurement information to another device via a wireless transmitter or wired data converter. After connecting a transmitter to the 10-pin output connector on the readout, the user can initiate the data transmission by momentarily pressing the **SEND** key. Pressing this key will cause **SEND** to appear on the screen for 1 second; this shows activation of the send function (even if no device is attached to the readout).

NOTES:

- All inch modes are transmitted as decimal inches.
- All metric modes are transmitted as millimeters.
- **Wired transmission devices should not be used if the encoder type is Model 150B or Model 250B.**

Offset Addition

(Not available on the Basic readout without an external device connected)

Some applications have multiple fixed reference positions to keep track of. The readout can be used to apply numerical offset values to the primary absolute position. The Offset Addition feature allows the readout to track up to 11 reference positions, and for the user to switch between these positions using the F1 key.

To enable the Offset Addition feature, first determine how many total reference positions you need to track. Subtract one from the total, then program this number into parameter Pr30.

For example, imagine you have one primary reference position, plus a second fixed position that is 5.225 inches away, and a third fixed position that is 15.625 inches from the primary.

Enter the programming menu (see page 26) and go to Pr30 (page 30). Set to this a value of 2 (because there are 2 extra reference positions).

Next, program Pr31 to +5.225 inches, and program Pr32 to +15.625 inches. Exit the programming menu.

After the readout is calibrated for the distance to your primary reference:

- Press the F1 key to apply the first offset. The readout will add 5.225 inches to the primary value. You will also see a small **1** appear above the measurement.
- Press the F1 key again to apply the second offset. The readout will add 15.625 inches to the primary value, and a small **2** will appear above the measurement.
- Press the F1 key again to show the primary value (no offsets applied).

NOTES:

- All offset values are with reference to the primary (not the previous offset).
- Offset values are applied after non-linear compensation, temperature compensation, and secondary multiplier (Pr16) are all processed.

Operation: Advanced Functions

(Not available on the Basic readout)

Advanced functions allow the readout to perform special tasks using the F1, F2, F3, and F4 keys. These special tasks must be enabled using programming parameter Pr24. The table below provides a summary of the functions available.

Programming Parameter Pr24 Value	Function
0	No Advanced Functions (default)
1	F3 = MON, F4 = HOLD
2	Go / NoGo operation

Monitor (Drift Monitoring)

(parameter Pr24 set to 1)

The readout can be used to monitor a position (to detect drift or variance). To activate the monitor mode, first set programming parameter Pr24 to 1. After this is activated, position the measuring system at the desired location, then *momentarily* press the **F3** key. The **MON** symbol will illuminate on the LCD to indicate the monitor mode is active.

If the measuring system moves more than 0.010 inches in either direction, all digits on the screen (plus the **MON** indicator) will flash. If the measuring system is moved back into position, the flashing will stop.

To exit the monitor mode, *momentarily* press the **F3** key. The **MON** symbol will turn off.

Notes:

1. The tolerance zone can be customized by changing the value of programming parameter Pr26.
2. Monitor can be activated in ABS or INC measuring mode. If a change is made to/from absolute and incremental modes, the monitor feature will be deactivated.
3. When a drift condition occurs (motion made outside the tolerance zone occurs), the readout will temporarily show **DRIFT** on the screen, then the digits will begin flashing. If the drift condition ends (position is returned to the tolerance zone), the readout will show **IN POS** for a moment.
4. The readout can output a signal when the drift condition occurs. This requires a male terminal strip be added to the readout and wired to common and I/O pin, as shown on page 9.
5. If the monitor mode is enabled and the programmable output is configured for drift monitoring (programming parameter Pr38), the output becomes active after sustained drift condition for at least 2 seconds.

Hold

(parameter Pr24 set to 1)

The readout provides a feature that allows the displayed measurement or position to be put on “hold”. This allows information to be captured on the readout for later viewing, regardless of the current encoder position.

To activate the monitor mode, first set programming parameter Pr24 to 1.

To activate the HOLD feature, *momentarily* press the **F4** key.

HOLD will be displayed in the upper left corner of the LCD.

The currently displayed position and most key presses will be held.

To release the HOLD feature, *momentarily* press the **F4** key again.

NOTES:

- While in HOLD mode, the screen will actively flash HOLD and then the frozen dimension.
- Keypresses while in HOLD mode will be executed when HOLD mode is released.
- Leaving the normal measurement mode, (i.e. enter programming mode) causes the readout to automatically exit HOLD.

Go/NoGo

In certain applications, it may be desirable to program upper and lower measurement tolerances to measure parts. If the measurement falls within the programmed tolerance, a “Go” condition occurs. If the measurement is not within the upper or lower tolerance, a “No Go” condition occurs.

To activate the Go/NoGo mode, first set programming parameter Pr24 to 2. Programming Parameter Pr25 should also be set to the number of target positions.

For example: You have 4 parts you want to use the Go/NoGo feature for. Enter the programming menu and set Pr24 to 2, then Pr25 to 4.

Setting up the Go/NoGo Ranges

The readout can store up to 32 measurement targets, each with its own unique upper and lower tolerance. Each measurement target is identified with a number from 1 to 32. The Go/NoGo Editor is used to enter individual upper and lower tolerances for each measurement target as follows:

1. Press **F3** to enter the editor. The LCD will display **nGO 1** (the 1 represents the first measurement target to be edited).
2. If this is the measurement target you wish to edit, proceed to step 3 below. If you wish to edit a different target, press the F3 again until the target you want to edit is displayed.
3. *Press and hold* the UNITS key, then *momentarily* press the **F4** key. The LCD will display **GO x U** for 1 second. The U represents the upper tolerance for this target. Use the **+** and **-** keys to set an upper limit.
4. *Momentarily* press **F3**. The LCD will now display **GO x L** for 1 second. The L represents the lower tolerance for this target. Use the **+** and **-** keys to set a lower limit.
5. Continue to press F3 and edit the next target's upper and lower values.
6. When done editing values, either:
Press F3 over and over until you reach end of the target values, or
Press and hold the UNITS key, then *momentarily* press the **F4** key.
The readout will show **Go OFF**.

Operation of Go/NoGo Feature

To count up through the list of measurement targets, press **F3**.

To count down through the list of measurement targets, press **F4**.

The Go/NoGo feature is activated immediately after a target is selected.

If the measurement is in tolerance, the readout will show the measurement for 3 seconds, then **GO**.

If the measurement is out of tolerance, the readout will show the measurement for 3 seconds, then **No Go**.

Notes:

- Once a measurement target is selected, the LCD will alternate between the current position and **GO** or **No Go**.
- The readout can output a signal when GO or NOGO are displayed. This requires a male terminal strip be added to the readout and wired to common and I/O pin, as shown on page 9. A light or siren could be connected and activated to provide additional feedback for an operator.
- When Go or NoGo is activated, and the programmable output is configured for Go/NoGo (programming parameter Pr38), the output will become active immediately.

Using Compensation Features

Your ProScale digital readout has several compensation tools built in. See table below for the available features:

	Primary linear correction	Non-linear (segmented) correction	Temperature compensation	Secondary linear multiplier
Basic	Yes	No	No	Yes
General	Yes	No	No	Yes
Enhanced	Yes	Yes	Yes	Yes

Primary linear correction is commonly used by the factory to correct for (coarse) linear error of the electronic scale. For instance, if the system reads +.005" over 5 inches, and .010" over 10 inches, and .015" over 15 inches, this could be corrected using linear compensation. Using a multiplier of 0.99900, the accuracy at all these locations would be much improved. We recommend using programming parameter Pr13 for this.

Non-linear compensation (sometimes called segmented compensation) is used to correct errors that the primary linear correction cannot fix. For instance, if the system reads +.005 at 5 inches, but -.005 at 10 inches, use of only the primary linear correction cannot suitably fix the error.

Temperature compensation (sometimes called thermal compensation) is used to correct variation of the **entire measuring system** due to changes in ambient temperature. For instance, if a ProScale system is mounted to an aluminum benchtop, the **entire system** will grow/shrink as temperature changes. This expansion can be corrected for using programming parameters Pr41 and 44. *Keep in mind that this feature corrects for the gage, but not for the product being measured. And it must be initialized to function properly (see page 37).*

Secondary linear multiplier is most commonly used to apply a final multiplier to all the corrected values. For example, if you were measuring the length of V-belt between two points, you might use primary linear, non-linear, and temperature compensation to optimize total gage accuracy. But since the V-belt has 2 lengths which are simultaneously measured between 2 points, the secondary linear multiplier could be used to make the readout show the total belt length (multiplier set to 2.0000).

If you are in doubt about which multiplier to use, and how they interact, please consult factory for assistance.

Using an External Input

The readout supports using 1 or 2 external pushbuttons, footswitches, etc to trigger regular display functions.

First, determine which function should be mapped to the external input. Then use the programming menu to set parameter Pr35 and Pr36 accordingly:

Programming Parameter Pr35 Setting:	Function that will be performed:
0	None
1	Send function
2	Datum function
3	Offset function
4	Units mode changes
5	Absolute/incremental mode

Notes:

- Use of an external input for Pr35 requires a male terminal strip be added to the readout and wired to common and I/O pin, as shown on page 9.
- Use of an external input for Pr36 requires soldering directly to the readout's circuit board (IN2 pad in upper right corner).
- The readout can only use Inputs or Output at any given moment; the features are mutually exclusive.
- **DO NOT APPLY VOLTAGE TO THE INPUT CONNECTOR. It should only be switched from OPEN to GROUND.**

Programming Mode (customizing the readout features)

Many functions of the digital readouts are user programmable and may need to be configured to optimize operation.

Resetting All Parameters

Resetting all parameters is not necessary if you wish to customize your system.

Caution: This step is not reversible. If you have purchased a complete product (turnkey gage, stop and fence system, etc.), some parameter settings differ from factory values. (*Special parameter settings for your product are detailed inside the front cover of your original user manual.*)

To reset all parameters to the FACTORY defaults:

1. Turn the readout power off with a quick press of the ON/OFF key.
2. Open the readout case and ensure the PGM ENABLE jumper connects pins 1 and 2. (This jumper is just to left of the negative battery terminal.)
3. *Press and Hold* the **ON/OFF** and **UNITS** keys for 15 seconds.

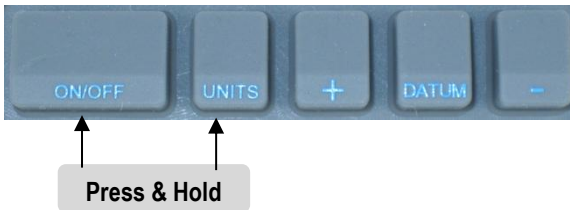

After these 15 seconds, the readout will:

1. Perform a full LCD segment test.
2. **Reset all programming parameters to factory default values.**
3. Display the firmware version.
4. Display **RESET** to indicate successful operation.

After the RESET message appears, the reset is complete, and the keys may be released. Be sure to program critical values before putting readout back into service.

How to Enter Programming Mode

Before making changes, open the readout case and verify the programming menu is accessible. The jumper to the left of the battery has three pins. Ensure pins 1 and 2 are connected with a shunt before proceeding. (After making changes, you can move the shunt to pins 2 and 3 to prevent further programming changes.)

Note: The programming menu uses the currently selected measurement units. If you prefer to customize programming settings in inches, be sure the screen is showing measurements in INCHES before entering programming mode.

To start the programming menu, turn on the readout.

1. Press and hold the UNITS key.
2. Quickly press and release DATUM key. You will see **PG on**, then **Pr1**.
3. Release the UNITS key. The value for Pr1 will display on right side of the screen.

How to Navigate and Use the Programming Mode:

To move up the parameter list:

Momentarily press the **UNITS** key to move up through the Programming Parameter list. After each press of the **UNITS** key, the readout will display the next parameter number, then its programmed value.

To move down the parameter list:

Press and Hold the **ON/OFF** key, then *Momentarily* press the **UNITS** key to move backward through the parameter list.

To Increase a parameter value:

Press the **plus (+)** key while the parameter value is displayed.

To Decrease a parameter value:

Press the **minus (-)** key while the parameter value is displayed.

To reset a parameter value to the Factory setting:

Momentarily press the **DATUM** key while the parameter value is displayed.

How to Exit Programming Mode

1. *Press and hold* the **UNITS** key.
2. *Momentarily* press the **DATUM** key.
3. The LCD will briefly display: **PG oFF** (Programming Off).
4. Release both keys.

NOTE: The readout will automatically exit programming mode if there is no key presses for 60 seconds.

Programming Parameters Details

Values in brackets [] represent the range of possible values available for that parameter.

Pr1 – Datum [0 to ± 999.999in]

The value that will be shown on the display when the **DATUM** key is pressed during normal operation.

Default Value= 0.000 inches

Pr2 – Reading Direction [0 or 1]

This parameter controls the direction displayed on the readout when the measuring system is moved. If the displayed value gets larger and it should be getting smaller, change this value (true for POSITIVE numbers only).

Default Value = 0

Pr3 – Programming LOCK..... [0 or 1]

In addition to the key combination on page 11 used to lock the keypad, this parameter also locks the keypad (disables +, - and **DATUM** keys).

Default Value = 0

Pr 3 Setting	Key Action
0	+, - and Datum keys respond normally
1	+, - and Datum keys are locked

Pr4 – Resolution [1, 2, 3 or 4]

This parameter sets the number of decimal places displayed on the readout.

Default Value = 3

Pr 4 Setting	Resolution inches	Resolution mm
1	X.X	X.X
2	X.XX	X.XX
3	X.XXX	X.XX
4	X.XXXX	X.XX

Pr5 – Movement to Wake Readout [0.004 to .400 inches]

This parameter defines how far the system must move to automatically turn the screen back on.

Default Value = 0.004 inches

Pr6 – Fractional Rounding [0 or 1]

This parameter is used to control how fractions round up or down

Default Value = 0

Pr 6 Setting	Fractions will
0	Round down
1	Round up

Pr7 – 4th decimal place in inches----- [0 or 1]

At its core, the system works in millimeters. When converting to decimal inches, and set to display 4 places, choose how the fourth place will appear.

Default Value = 1

Pr 7 Setting	4 th decimal place will
0	Display converted value from mm
1	Show only a 0 or 5

Pr10 – Modulation Time [0 to 4]

This setting controls how often the readout checks for position updates from an input device when the screen is turned off.

Default Value = 2

Pr 10 Setting	Displayable Units
0	No modulation
1	500ms modulation
2	1 second modulation
3	2 second modulation
4	No modulation. Best setting for when Mitutoyo or similar DTIs are used.

Pr11 – Available Units [0 to 6]

This parameter controls which measurement units are available when the UNITS key is pressed.

Default Value = 0

Pr 11 Setting	Displayable Units
0	All inch units and millimeters
1	Millimeters only
2	Decimal inches and millimeters
3	Decimal inches and centimeters
4	All inch units and centimeters
5	Centimeters only
6	Decimal inches only

Pr12 – Readout Auto-Off Time [0 to 240]

This parameter changes the number of minutes before the display turns off to conserve battery power. When this parameter is set to 0, the readout will not automatically power off.

Default Value = 15 (minutes)

Pr13 – Primary Linear Compensation [0.00001 to 9.99999]

This parameter applies a linear multiplier to the input value from the encoder. This multiplier is processed BEFORE offset values are applied.

Default Value = 1.00000

Pr14 – Encoder type [0 or 1]

This parameter sets the features available for incremental or absolute technology type encoders.

Default Value = 0

Pr 14 Setting	Technology Supported
0	Incremental scales/encoders
1	Absolute series scales/encoders

Pr15 – LCD Contrast [1- 15]

This parameter sets the LCD contrast value. (Higher numbers are better for direct viewing of the LCD.)

Default Value = 10

Pr16 – Secondary Linear Compensation [0.00001 to 9.99999]

This parameter applies a linear multiplier to the corrected value (after all compensation functions are performed). This multiplier is processed BEFORE offset values are applied.

Default Value = 1.00000

Pr17 – Enable Angle Measurement [0, 1, 2]

This parameter applies a mathematical formula that converts linear motion of an encoder to angular measurement over a small range of angles.

Default Value = 0

Pr 17 Setting	Angle mode enabled? Resolution inches
0	Measure length, not angles
1	Measure angles from 90 degrees at center (range is 85 to 95 degrees)
2	Measure angles from 0 degrees at center (range is -5 to +5 degrees)

Pr18 –Angle Pivot Distance [0.500 to 5.000 inches]

This parameter defines how far the linear encoder used is from the center of a pivot/bearing.

Default Value = 3.500 inches

Pr22 – ABS/INC Key Operation [0 or 1]

This parameter controls the amount of time the **ABS/INC** key needs to be pressed to enter the INC (incremental) measuring mode.

Default Value = 0

Pr 22 Setting	Key press to enter INCRemental mode
0	<i>Press and Hold ABS/INC key (1.2 sec)</i>
1	<i>Momentary depress ABS/INC key (< 1 sec)</i>

Pr23 – ABS/INC and SEND key operation..... [0 to 3]

The parameter can be used to deactivate the ABS/INC and/or SEND keys.

Default Value = 3

Pr 23 Setting	ABS/INC and SEND keys
0	Disable Both keys
1	Enable ABS/INC key only
2	Enable SEND key only
3	Enable both keys

Pr24 – Advanced Functions [0 to 4]

This parameter controls which Advanced Function set is active.

Default Value = 0

Pr24 Setting	Advanced Readout Function
0	None
1	F3 = MON, F4 = HOLD
2	Go/NoGo

Pr25 – Go/NoGo targets [0 to 32]

The parameter is used to set how many Go/NoGo target values are available for use.

Default Value = 0

Pr26 – Monitor/drift Tolerance [0.001 to 120 inches]

This parameter sets the amount of drift that must occur while in MON (monitor) mode to trigger a drift indication.

Default Value = .010 inches

Pr27 – Upper & Lower Limits [0 or 1]

This parameter turns on the limits function. (Be sure to set Pr28 to the lower limit & Pr29 to the upper limit).

Default Value = 0

Pr 27 Setting	Upper/Lower Limits Function
0	Function disabled
1	Function enabled

Pr28 – Lower Limit Value [0 to ± 999.999in]
 This value sets the lower limit of Upper/Lower Limits function.
Default Value = 0.000 inches

Pr29 – Upper Limit Value..... [0 to ± 999.999in]
 This value sets the upper limit of Upper/Lower Limits function.
Default Value = 5.000 inches

Pr30 – Offset Addition [0 to 4]
 This parameter sets how many offsets are available for the offset additions.
 Note: Pr31, Pr32, Pr33, and Pr34 set the value of the offsets used.
Default Value = 0

Pr30 Setting	Offsets Enabled
0	None
1	Offset 1 Enabled
2	Offsets 1 & 2 Enabled
3	Offsets 1, 2 & 3 Enabled
4	Offsets 1, 2, 3 & 4 Enabled

Pr31 – Offset 1 [0 to ± 999.999in]
 This value is added to the current measurement when Offset Addition is enabled and the F1 key is pressed.
Default Value = .500 inches

Pr32 – Offset 2 [0 to ± 999.999in]
 This value is added to the current measurement when Offset Addition is enabled and the F1 key is pressed.
Default Value = 2.000 inches

Pr33 – Offset 3 [0 to ± 999.999in]
 This value is added to the current measurement when Offset Addition is enabled and the F1 key is pressed.
Default Value = 3.000 inches

Pr34 – Offset 4 [0 to ± 999.999in]
 This value is added to the current measurement when Offset Addition is enabled and the F1 key is pressed.
Default Value = 3.000 inches

Pr35 – External Function Mapping [0 to 5]

This parameter maps the function that is performed when an external input signal is sent to the 3 position terminal strip.

Default Value = 0

Pr35 Setting:	Function that will be performed:
0	None
1	Send function
2	Datum function
3	Offset function
4	Units mode changes
5	ABS/INC mode change

Pr36 – Same as Pr35, except input connection is IN2 on circuit board.

Pr37 –Output Polarity [0 or 1]

This sets the normal state of the programmable output (when **not** activated)

Default Value = 0

Pr 37 Setting	Output Polarity
0	Normally Open (NO)
1	Normally Closed (NC)

Pr38 –Output Function [0 to 3]

Selects the function that the programmable output works with.

Default Value = 0

Value of Pr 38	Function
0	No Operation
1	Monitor (Drift) Operation
2	Upper/Lower Limits
3	Go/No Go

Pr39 – Non-Linear Compensation [0 or 1]

This parameter enables or disables the Non-Linear Compensation feature.

Default Value = 0 (off)

Pr 39 Setting	Non-Linear Compensation
0	Off
1	On

Pr40 – Non-Linear Compensation Interval [0.5 to 10.0 in.]

This parameter sets the distance/step/segment length used while performing non-linear compensation calibration.

Default Value = 5.000 inches

Pr41 – Temperature Compensation [0 or 1]

This parameter enables or disables the temperature compensation feature.
(This feature must be initialized to function properly.)

Default Value = 0 (off)

Pr44 – Temperature Compensation Coefficient [10 to 999]

This parameter sets the temperature expansion coefficient used when temperature compensation is turned on.

Default Value = 150

Range: 10 to 999 will yield values from 1.0 m/m °K x 10⁻⁶ to 99.9 m/m °K x 10⁻⁶.

Note: Coefficients MUST be in m/m °K.

Pr45 – Offset 5 [0 to ± 999.999in]

This value is added to the current measurement when Offset Addition is enabled and the F1 key is pressed.

Default Value = 3.000 inches

Pr46 – Offset 6 [0 to ± 999.999in]

This value is added to the current measurement when Offset Addition is enabled and the F1 key is pressed.

Default Value = 3.000 inches

Pr47 – Offset 7 [0 to ± 999.999in]

This value is added to the current measurement when Offset Addition is enabled and the F1 key is pressed.

Default Value = 3.000 inches

Pr48 – Offset 8 [0 to ± 999.999in]

This value is added to the current measurement when Offset Addition is enabled and the F1 key is pressed.

Default Value = 3.000 inches

Pr49 – Offset 9 [0 to ± 999.999in]

This value is added to the current measurement when Offset Addition is enabled and the F1 key is pressed.

Default Value = 3.000 inches

Pr50 – Offset 10 [0 to ± 999.999in]

This value is added to the current measurement when Offset Addition is enabled and the F1 key is pressed.

Default Value = 3.000 inches

Pr60 – Pr63 These are internal fault counters, used only for factory trained technician's diagnostics. (These values are cleared by a factory reset).

Non-linear compensation

The non-linear compensation function is used to enhance the basic accuracy of a ProScale based system by creating a table of correction values in the readout. These correction values are based on known measurement points along the length of the measurement system. The compensation table in this readout can store up to 300 correction values. (This feature is only available on Enhanced type ProScale readouts.)

Several factory assembled gages - including ProPanel and ProTable – often have this process completed at the factory prior to shipment. It is not necessary to repeat the initial error compensation procedure unless a system component has been replaced (readout or electronic scale). *However, if there is reason to believe a product could have been damaged, repeating this process is encouraged.*

For ProKit Model 590 systems, the initial error compensation procedure should be performed AFTER product is installed for the correction values to be meaningful.

Preparing for non-linear compensation

Your digital readout MUST BE IN ABS MODE for the calibration data to be useful. (If the readout is in INC mode, press and hold the ABS/INC key until the ABS indicator lights in the upper left corner of the LCD.)

Before beginning the non-linear error compensation procedure, determine how many correction points you will use. You also need to determine the interval which will be used. The readout can store up to 300 correction points. The smaller the compensation interval (more points), the smoother the corrected calibration curve will be. However, this equates with more time spent, and more gage blocks are required.

Quality measurement standards such as square or rectangular Gage Blocks should be used. Keep in mind, however, that you will need enough standards to create the number of points you decide to correct.

Example: For a measuring system 100 inches long, you might elect to correct every 2.000 inches along the full range. In this case, you will need sufficient standards to create a known measurement correction point EVERY 2.0000 inches over that full measuring range. A more realistic approach would be to use an interval of 5.000 inches (which requires fewer gage blocks and much less time).

Performing the non-linear compensation process

The following example uses 5.000-inch gage blocks and a ProTable-SA Linear Measuring Machine. Other applications would follow a similar procedure.

1. Access the programming menu and set parameter Pr39 to a value of 1. Also set parameter Pr40 to your compensation interval. (For this example, the setting is 5.0000 inches.)
2. If you are using temperature compensation, Pr41 should be set to 1 now.
3. Exit the programming menu.
4. Turn off the readout using the ON/OFF key.
5. Press and hold the DATUM key and the ON/OFF key until the readout powers on (about 10 seconds). The screen will power on, show the firmware version, then show **CAL**.
6. The current position and the CAL message will alternate on the screen. This indicates the readout is ready to start recording compensation points. This alternating display will continue throughout the calibration process.
7. Place the measuring system's moving carriage against the fixed jaw/stop. Press the DATUM key to zero the measurement.
8. Press the **F1** key. This enters the first correction point into the table. The LCD will momentarily show **CO 0**. This indicates the zero position entry was accepted. The display will then briefly display the next *expected* position (5.0000 in this case).
9. Open the carriage and place the first measurement standard (5.000 inches) between the jaws. Close the moving carriage until the face of the jaw gently touches the standard. Press the **F1** key. The LCD will show **CO 1** indicating the first measurement point has been digitized. The display will briefly display the next *expected* position (10.0000 in this case). *Note: If the screen shows **BAD PT**, press F2 key to exit the calibration process; see next page for details.*
10. Open the carriage and insert another measurement standard (total of 10.000in) between the jaws. Close the moving carriage until the face of the jaw gently touches the standard. Press the **F1** key. The LCD will show **CO 2** briefly. The display will then briefly display the next *expected* position (15.0000 in this case).
11. Repeat above steps with additional standards placed end-to-end every 5.000" (pressing F1 key each time) until the maximum measuring range has been achieved.

-
12. After the last correction point has been digitized by pressing F1, end the calibration process by pressing the F2 key. The LCD will momentarily show **CO END**. This indicates that the calibration process has ended. The readout will immediately return to normal operation.

Notes about the calibration process

- If you see **BAD PT** during the process, either the setting for programming parameter Pr40 does not match the gage bars used, or the product has too much error to be calibrated.
- During the calibration process you may want to verify the NEXT correction point to be saved. This can be accomplished by *momentarily* pressing the F3 key. The LCD will display the next expected value to be programmed for a moment.
- If an error is made during the calibration process where an incorrect entry is recorded, press the F4 key to back up one position. The screen will show **CD x** (where x is the correction entry number).

Operating in Compensated mode

After a successful correction table has been programmed, the readout will operate normally, and the measuring system will have a higher level of accuracy.

If the system is positioned outside the calibrated (corrected) range of operation, the LCD will display **NO CO** alternately with the current position. This is normal and indicates that the system is operating outside the zone where it was calibrated. For example, if you calibrated from 0-100 inches, and the readout is showing -.001 inches, or 100.250 inches, the **NO CO** message is expected.

If you choose to turn off non-linear compensation (set Pr39 to 0), the compensation table will be saved in memory.

NOTE: Resetting the digital readout to factory defaults does not erase the compensation table.

Enabling Temperature Compensation

Gages which are fully built by Accurate Technology already have this feature enabled. No further actions are needed.

If you have built your own gage or replaced an original Readout with a new unit, this process may be required. Consult the factory if you are not sure.

To use Temperature Compensation:

1. Enable programming parameter Pr41 (set it to 1). See pages 26 and 33 for more details on the steps for this.
2. Enable programming parameter Pr44 (set it to CTE value). See pages 26 and 33 for more details on the steps for this.
3. Initialize the temperature module: follow steps 2-8 on page 35.

Notes:

- A. The default CTE value for Pr44 is 150. This value is derived by factory tests of thermal expansion of the ProTable-SA gage. (This gage is constructed of both aluminum and steel, so the optimized CTE value is partway between an aluminum-only or steel-only value.)
- B. If you will not use the non-linear programming features, the temperature module still needs to be initialized using steps 2-8 on page 35. After step 8, press the F2 key. Then change programming parameter Pr39 to 0 setting.
- C. If you use Temperature Compensation and LINEAR compensation, it is recommended to initialize the temperature module before computing and entering a value for Pr13 other than 1.00000.
- D. Failure to initialize the temperature module will result in erroneous corrections as gage temperature varies.

Locking out access to the programming menu

After all changes are made to the programming menu, access can be blocked by changing the position of a jumper on the circuit board.

Open the readout case and locate the jumper. There are three copper pins to the left of the battery. Two of these pins are connected with a shunt. To disable the programming menu, join pins 2 and 3 using the jumper.





Close the readout case.

If access to the menu is needed later, open the case and move the jumper to join pins 1 and 2.

Error & Alert Messages

Message	What it means
<i>F Err</i>	The readout is attempting to display a fractional value larger than 399 63/64ths
<i>no Enc</i>	There is not an encoder connected to the readout, or the connected encoder has a fault.
<i>no PoS</i>	The readout has not been calibrated yet, or when an inductive type encoder is connected after power/signal failure. This message indicates that the displayed position may not be valid.
<i>DISABL</i>	Displays if the ABS or SEND keys are pressed but their functions are disabled in programming.
<i>SEND</i>	The SEND function was activated.
<i>LOCK</i>	The keypad is in LOCK mode, but an attempt was made to change the calibration. Unlock the keypad to fix this.
<i>P LOCK</i>	The keypad is LOCKed, but an attempt was made to change the calibration. Change programming parameter Pr3 to fix this.
<i>no oFF</i>	Offsets are disabled, but an attempt was made to apply an offset value.
<i>MON</i>	Monitor mode is turned on, and the system is out of the allowable tolerance zone.
<i>No Co</i>	Non-linear compensation is enabled, but there is no look-up data for the displayed measurement.
<i>UNDEF</i>	Shows when F3 is pressed while in Non-linear calibration mode and no points are currently stored. Also displays when F4 is pressed and no points are currently stored.
<i>Co x</i>	A compensation point was stored to memory.
<i>BAD PT</i>	The current value is not close enough to the expected compensation value.
<i>CD x</i>	The previously entered compensation point was deleted.
<i>Co END</i>	Compensation entry has been completed.
<i>Hi LMT</i>	A programmed upper limit has been exceeded.
<i>Lo LMT</i>	A programmed lower limit has been exceeded.
<i>RESET</i>	The programming parameters were reset to factory defaults.
<i>No PGM</i>	Access to the programming menu was attempted, but it is currently locked out (see page 38).
<i>NO BAT</i>	The readout was powered on with an external power connection, but a backup battery is not installed.
<i>E Warn</i>	The connected encoder is drawing too much current and battery life will be reduced.

Accessories

<p>External Power and I/O plug Part number 200-1016-001. Adds external power and/or input/output capabilities to the readout.</p>	 A black plastic component with several rectangular ports on the front and a circular opening on top.
<p>Switching power supply Part number 550-2003-001. Provides 15VDC power to the readout.</p>	 A black rectangular power supply unit with a power cord and two output wires.
<p>Wireless Data Transmitter Part number 700-1037-004. Transmits measurement values to a remote computer. With proper configuration, the readout's battery can be used to power this transmitter (see transmitter's User Manual for details).</p>	 A blue ProScale transmitter device with a screen and buttons. A label above it reads "PROSCALE SPC TRANSMITTER" and lists "MESSAGE SENT" and "LOW BATTERY" indicators. The device has buttons labeled "ADD TEST", "SEND", "F1", "F2", "F3", "F4", "CHGRT", "BATT", "SEARCH", and "EXIT".

Popular ProScale Products

ProStop is a complete Digital Stop and Fence System for miter and chop saws. It includes an aluminum Fence, a Flip-Stop with fine adjust control, double locks, and Quick-Sets. Many add-on plates available too!

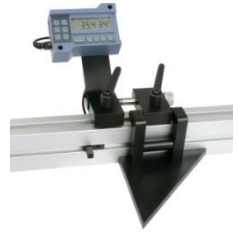

ProPanel is a GIANT DIGITAL CALIPER used to make inside, outside, diagonal, hole-to-edge and hole-to-hole dimensional measurements. This is a rugged linear measuring tool designed to make "on the manufacturing floor" measurements.



ProKit 590 is an ideal foundation for a 'build-it-yourself' dimensional measuring system. ProKit 590 is available in measuring lengths up to 190 inches (4.8m). SPC output comes standard. Wireless data transmitter is available.



ProTable-SA is a self-contained, single axis measuring table/QC station. Leg sets and casters make this product easy to move around the manufacturing floor. Temperature compensation and non-linear error correction are built into the readout. Systems are available up to 24 ft. long. Accuracy within +/- .003 inches over the entire range. SPC output and temperature compensation are included. Custom configurations are available in one or two-axis versions.



ProTable-CAB is a two-axis measuring system designed for quick and affordable length and width measurements of cabinet doors or other panel type products. It can be configured to include angle and out-of-square measurements.



Thank you for choosing a ProScale Product,

IT WAS PROUDLY MADE IN THE USA



Accurate Technology, Inc.

270 Rutledge Rd. Unit E

Fletcher, NC 28732 USA

1-828-654-7920

www.proscale.com