

Accurate

TECHNOLOGY INC.

Linear Digital Measuring Systems



¼ DIN size Panel Mount LCD Readout
#700-1600-445

This guide applies to ProScale digital readouts with Firmware Version 4.02 to 4.100. (The firmware version is displayed on power-up.)

If your readout has a different firmware version, this manual should not be used. Consult factory for assistance.

PROSCALE PANEL MOUNT LCD READOUT INSTALLATION & OPERATION

Readout serial # _____

Date of purchase _____

The following programming parameters have been pre-configured at the factory for this readout. (If blank, settings are at defaults):

Parameter Pr2 (Reading Direction) _____

Parameter Pr13 (Linear Multiplier) _____

Parameter Pr14 (Compatibility) _____

If your digital scale has this pattern, be sure Parameter 14 is set to 1.



For all other electronic scale patterns, set Parameter Pr14 to 0.

Programming menu access is disabled? _____

SAFETY WARNING
BEFORE INSTALLATION ON ANY MACHINERY:
TURN OFF MACHINE AND DISCONNECT POWER

Contents

INTRODUCTION	5
SPECIFICATIONS	6
INSTALLATION	6
POWER AND INPUT-OUTPUT CONNECTIONS	7
INITIAL SETUP	8
KEYS ON THE READOUT	9
WHAT DO THE SYMBOLS MEAN?	10
OPERATION & CUSTOMIZABLE FEATURES	12
AUTOMATIC POWER OFF:	12
AUTOMATIC POWER ON:	12
AVAILABLE UNITS:	12
RESOLUTION:	12
LOCK:	12
LINEAR SCALING:	13
SEGMENT CORRECTION:	13
LIMITS:	13
ABSOLUTE / INCREMENTAL MODES:	14
OFFSET ADDITION	15
USING AN EXTERNAL INPUT	16
PROGRAMMING MODE (CUSTOMIZING THE READOUT FEATURES)	17
RESETTING ALL PARAMETERS	17
HOW TO ENTER PROGRAMMING MODE	18
HOW TO NAVIGATE AND USE THE PROGRAMMING MODE:	18
HOW TO EXIT PROGRAMMING MODE	18
PROGRAMMING PARAMETERS DETAILS	19
LOCKING OUT ACCESS TO THE PROGRAMMING MENU	24
ACCESSORIES	26
POPULAR PROSCALE PRODUCTS	27

Introduction

This manual includes operation and use information for installation and customization of ProScale panel mount readouts that have firmware version 4.020 to version 4.100 (The firmware version is displayed when the readout is powered on using the ON/OFF key.)

This digital readout may be supplied as part of ProScale linear encoder system, or as part of a turn-key measuring gage built and supplied by Accurate Technology, Inc.

Videos showing many features of this readout are available at www.proscale.com – be sure to search by your readout's Part Number to see features that are available for it.

The readout covered in this Manual is compatible with electronic scales that have the following colors and patterns:

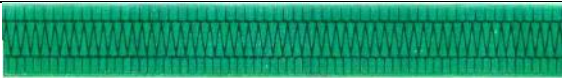

Green 'zig-zag' pattern is used on ProScale Models 150B, 250B, 950, 150G, and 250G **Absolute Series** measuring systems.

For this scale pattern, programming parameter Pr14 should be set to 1.

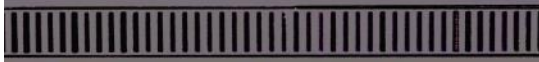

Black 'stripes' pattern is used on ProScale Models 190, 290, 390 & 590 systems **Inductive Series II** measuring systems.

For this scale pattern, programming parameter Pr14 should be set to 0.



Blue 'stripes' pattern was used on ProScale Models 180, 280, 380 & 580 systems **Inductive Series I** measuring systems – made 2007 to 2012.

For this scale pattern, programming parameter Pr14 should be set to 0.



Green 'stripes' pattern was used on ProScale Models 100, 200 systems – made from 1989 to 2010. **This readout has limited compatibility with this scale type; not recommended for long term use.**

Note: This manual is not meant to be 100% comprehensive. There are too many possible uses for these products to address every possible application. Further, the development of this readout model is forever ongoing, and features are being added all the time.

Specifications

Display Range: Inches: ± 999.999 inches
Millimeters: ± 9999.99 mm
Centimeters: ± 999.999 cm
Fractions: $\pm 399 \frac{63}{64}$ inches

Resolution: Inches: 1, 2, 3, or 4 decimal places
Millimeters: 1 or 2 decimal places
Centimeters: 1, 2, or 3 decimal places
Fractions: $\frac{1}{16}^{\text{ths}}$, $\frac{1}{32}^{\text{nds}}$, or $\frac{1}{64}^{\text{ths}}$

Operating Power: 1 CR123 Battery, or 12-24 Volts DC

NOTE: If external power and battery power are connected, the readout will automatically use the external power source when available.

External power should not be used if the electronic scale is either Model 150B or Model 250B.

Operating Temperature: 32 to 120°F (0 to 50°C) – **INDOOR USE ONLY**

Input: 6 pin connector for ProScale encoders only.

The terminal strip allows connection of a footswitch or pushbutton control for keypad emulation.*

Output: SPC Port: Compatible with most Digimatic type collectors, printers, converters.
Note: The SPC port only works with devices that remotely request information, or when an external button/switch is connected to input terminal strip.

The terminal strip can be used for output ALERTS when using Limits features.

* The terminal strip/plug can only be used for input or output features; both cannot be used at the same time.

Installation

A cut out in a panel should be made at least 90x90mm (3.60 x 3.60 inches), but no larger than 93x93mm (3.70 x 3.70 inches).

The front and rear parts of the readout case are designed to “sandwich” panel thicknesses between 3mm and 20mm (.125 and .75 inches).

If the panel is thinner than 3mm, shorter 4-40 threaded screws must be used for the readout readout’s installation, or damage to the front cover will occur.

Power and Input-Output Connections

This readout is powered by a single CR123 lithium battery. Unless specially ordered, the readout will deliver to you with the battery installed.

New for this version readout:

A battery indicator will appear on the left side of the LCD screen. There are 3 tiers of battery shown, which represent the voltage level of the battery. When only one tier is left, a new battery should be prepared for installation. Typical battery life for this readout is 7 months, but life will depend on how often the readout is being used, and which programming options are enabled.



Battery Replacement:

1. Locate the backside of the readout.
2. Remove the battery retainer clip.
3. Remove old battery.
4. Insert new battery, noting proper orientation.
5. Reinstall retainer clip.



External Power:

This readout also supports use of external power if:

1. The scale type is any model **except** Model 150B or Model 250B type. (Consult factory for assistance if scale type is not known.)
2. The input power is 12 – 24 volts DC. (AC power sources are not supported.)
3. Power is connected as noted just above the 3 position terminal strip.
4. Common for the machine and the readout must be the same. A “hot chassis” condition may permanently damage some or all of the electronics.

New for this version readout:

If external power is used, but a power loss occurs, the readout will automatically switch to battery power (if a battery is installed).

The readout will automatically switch back to external power when it is restored.

Initial Setup

Follow these steps to configure your readout for initial use:

1. When the readout is first powered on, it may show a **No Enc** message. This means there is not an encoder connected to the readout. To clear the message, connect a compatible encoder.
Note: Encoder must be installed onto scale first.
2. When an encoder is first connected, the readout may show **No Pos.** This informs the user that a position has not been programmed yet. For the initial setup, use the DATUM, and PLUS keys to set a **POSITIVE** starting value. (Any POSITIVE value will work for now.)
3. Choose the units that will be initially used (millimeters, inches, or fractions). Each press of the UNITS key will change the units that are displayed. (The screen will show the units description each time the UNITS key is pressed.)
4. Check the reading direction:
 - a) With the readout showing a POSITIVE number on the screen, move the encoder system a short distance.
 - b) Take note if the displayed value increased or decreased.
 - c) If the displayed value got larger/smaller, and this **IS** correct for your installation, no further steps are needed.
 - d) If the displayed value got larger/smaller, and this **IS NOT** correct for your installation, the reading direction needs to be reversed. This can be accomplished two ways:
 - i. If your encoder system is a Model 19, 29, 190, 290, 390, or 590 type, you can rotate the encoder 180 degrees on the scale.
 - ii. If the encoder cannot be rotated, or if the encoder is a Model 150 or Model 250 system, the reading direction must be reversed using the programming mode, parameter Pr2. See pages 17-22 for making programming changes.
5. Calibrate the readout. Since there are many thousands of applications for ProScale systems, all calibration methods cannot be described here. However, the general steps are the same.
 - a. Determine what value the readout should be showing.
 - b. Use the DATUM, PLUS, and MINUS keys to adjust the reading on the screen to match desired value. NOTE: To rapidly adjust the value, press and hold the PLUS or MINUS key down. (The update speed will increase every 2 seconds the key is held.)

Keys on the readout

All the keys on the keypad have multiple functions.



What happens on a **QUICK PRESS** of each key?

Key	Action
ON/OFF	The readout turns on or off.
UNITS	The units change. <i>Note: Available units can be restricted with custom programming settings.</i>
PLUS	The displayed value is increased one unit.
DATUM	The displayed value is set to the pre-programmed datum value. <i>Note: This value is zero by default, but it can be custom programmed to be any value.</i>
MINUS	The displayed value is decreased one unit.

What happens if a **KEY IS HELD DOWN**?

Key	Action
ON/OFF	Nothing
UNITS	Nothing
PLUS	The displayed value increases faster each 2 seconds.
DATUM	After 4 seconds, the battery voltage is displayed. After 7 seconds, the readout's temperature is displayed.
MINUS	The displayed value decreases faster each 2 seconds.

Key COMBINATIONS:

For these actions, **press and hold the first key**, then **quickly press and release** the second key. (*This action is the same as making a capital letter on a computer; the first key acts like SHIFT.*)

Press and hold	Then quickly press and release	Action
ON/OFF	UNITS	LOCK (or unlock) the keypad.
UNITS	DATUM	Enters or exits the programming mode.
UNITS	PLUS	Adds one segment to displayed value. (<i>Models 150/250 only.</i>)
UNITS	MINUS	Adds one segment to displayed value. (<i>Models 150/250 only.</i>)



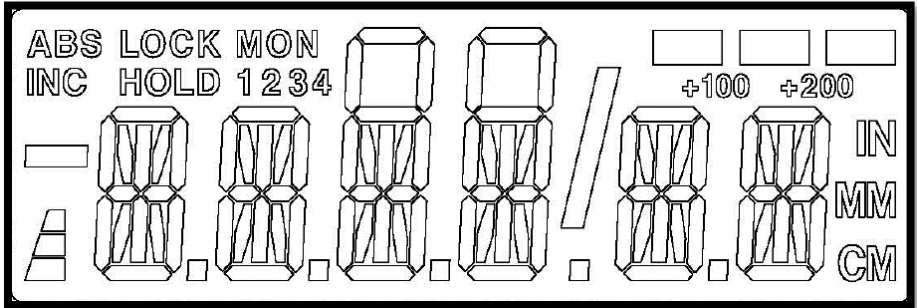

[Note: Additional key combinations exist, and more detail is provided later in this manual, where applicable.](#)

What do the Symbols mean?



Symbol	Meaning
ABS	The digital readout is operating in Absolute measurement mode.
INC	The digital readout is operating in Incremental (temporary) mode. Press and hold ABS/INC key 3 seconds to go back to ABS mode.
LOCK	The readout is in LOCK mode. This prevents loss of calibration if PLUS, MINUS, or DATUM keys are pressed. See page 8 for key combination to turn this off.
HOLD	No function on this readout model.
MON	No function on this readout model.
1 2 3 4	When any of these are displayed, the readout is adding a programmed offset value to the primary dimension. Offsets are useful for applications with multiple fixed data points.
	These are used with 16 th and 32 nd fractional inch modes. Each bar represents an extra 1/64 th long/heavy on the dimension.

Symbols (continued):

	When using fractions over 99 inches, one (or both) of these will light to show a value over 100 inches. For example: measurement is 205 5/16. The readout will show 5 5/16 and turn on the +200 indicator.
	Minus sign. Turns on when a negative value is displayed.
	Battery level indicator. When all 3 bars are lit, your battery is good. When only bottom bar is lit, a new battery is needed soon.
	Vinculum – used in fractions mode to separate numerator from denominator.
	Units indicator. IN is for INCHES or fractions. MM for millimeters. CM for centimeters. (Press UNITS key to change.)

Operation & Customizable Features

All of the keys on the readout have multiple functions and some also have key combinations for extra controls. See page 8 for more information about how the keys work separately and in combination.

Some customization and operation features require changing parameters in the programming menu. See pages 17-22 for more information about using the programming menu.

Automatic power off: To prolong battery life, the readout has a built-in timer that turns off the LCD screen after 15 minutes of inactivity. If you wish to shorten or extend this timer, use the programming menu to change parameter Pr12 (see pages 17-22).

Automatic power on: If the LCD is off, and there is motion greater than 0.10mm (.004 inches), the screen will wake up automatically. If you wish to increase this amount, use the programming menu to change parameter Pr5 (see pages 17-22).

Available units: By default, the readout can display measurements in millimeters, decimal inches, fractional inches (16th, 32^{nds}, and 64^{ths}). If you wish to restrict the units available for display, use the programming menu to change parameter Pr11 (see pages 17-22).

Resolution: By default, the readout displays millimeters to 2 decimal places, and decimal inches to 3 places. If you wish to change the resolution of displayed measurements, use the programming menu to change parameter Pr4 (see pages 17-22).

NOTE: The display will auto-range when needed. For example, if you configure the readout to show 4 decimal places in inches, but the measurement exceeds 99.9999 inches, the LCD screen does not have enough characters to show all digits. The readout will automatically reduce the decimal places to 3 when this happens.

LOCK: A user can “lock-out” the position adjustment keys (**PLUS, datum & MINUS**) to prevent accidental changes of the displayed value. See page 8 for the proper key combination. The word **LOCK** will display in the upper left corner of the LCD.



To deactivate this Key Lock, use the same key combination.

NOTE: Key Lock may also be enabled using the programming menu, parameter Pr3 (see pages 17-22).

In some cases, changing both parameter Pr3 to 0, AND the key combination may be needed to unlock the readout.

Linear Scaling: In some installations, it may be desirable to apply a linear adjustment. For instance, you may want to fine-tune the system using a small adjustment value like 0.99999. Or, you may want the readout to display double the actual motion made by the encoder using a value like 2.00000. Both parameters Pr13 and Pr16 can be used for this purpose. See pages 17-22 to change these.

Segment Correction: When using ABSOLUTE SERIES type scales, the maximum slew rate (how fast encoder can be moved) can be as low as 10 inches per second (depends on encoder used and which features of the readout are turned on). If the encoder is moved too quickly, the readout can lose its count of scale "segments". When this happens, the displayed value will be incorrect by 430mm (either too large or too small, based on the direction of travel). If this happens, the displayed value can be quickly corrected:

- To **add** one segment to the displayed value:
Press and Hold UNITS key and then Momentarily press the + key. The display will increase by 430.08mm (16.933 inches).
- To **subtract** one segment from the displayed value:
Press and Hold UNITS key and then Momentarily press the – key. The display will decrease by 430.08mm (16.933 inches).

Note: Segment correction only works when programming parameter Pr14 is configured to 1.

Limits: The readout can be programmed to alert the user when an upper or lower limit is reached. To enable this feature, use the programming menu to change parameter Pr27 to a value of 1 (see pages 17-22). Program the lower limit value in parameter Pr28. Program the upper limit value in parameter Pr29. During normal operation (between the limit values), the LCD will show the current measurement. When the displayed position moves outside the limits, the readout will alternate the position with either **HI LMT** or **LO LMT** on the screen.

The readout can also output a signal when limits are exceeded. This requires a connection to the terminal strip's I/O plug. (The output signal is set to NO or NC by parameter Pr37.)

Angle: The readout can be configured to compute and display angular measurements over a limited range (85 to 95 degrees). A ProScale linear encoder is the only input supported for this application.

Absolute / Incremental modes:

(Only works with an external button/switch)

The readout has two measurement indexes. One is called ABS (absolute) and the other INC (incremental). The ABS measurement is the reference distance to a fixed or known position. The INC measurement is a **temporary** point-to-point distance used only to make incremental/relative movements from one position to another. These modes are analogous to the odometer and tripmeter in your car.

The readout automatically enters ABS mode when power is first applied. This is indicated by **ABS** shown in the upper left corner of the LCD. To enter INC (Incremental) mode, *momentarily press external button*. The **ABS** indicator will turn off and an **INC** indicator will turn on.

When INC mode is initially entered, the displayed position will change to reflect a new reference point at the current position of the encoder. This is typically a position of zero but may be changed by using the **+** or **-** keys to enter an offset. Moving the encoder in either direction will display the distance moved from the initial INC starting point (plus any offset).

To return to the ABS mode, *momentarily press external button*.

Offset Addition

(Only works with an external button/switch)

Some applications have multiple fixed reference positions to keep track of. The readout can be used to apply numerical offset values to the primary absolute position (the primary is the distance from the “main” zero point to the encoder’s current place). The Offset Addition feature allows the readout to track up to 5 reference positions, and for the user to switch between these positions using an external button.

To enable the Offset Addition feature, first determine how many total reference positions you need to track. Subtract one from the total, then program this number into parameter Pr30.

For example, imagine you have one primary reference position, plus a second fixed position that is 5.225 inches away, and also a third fixed position that is 15.625 inches from the primary.

Enter the programming menu (see page 17) and go to Pr30. Set to this a value of 2 (because there are 2 extra reference positions).

Next, program Pr31 to +5.225 inches, and program Pr32 to +15.625 inches. Exit the programming menu.

After the readout is calibrated for the distance to your primary reference:

- Press the external button to apply the first offset. The readout will add 5.225 inches to the primary value. You will also see a small **1** appear above the measurement.
- Press the external button again to apply the second offset. The readout will add 15.625 inches to the primary value, and a small **2** will appear above the measurement.
- Press the external button again to show the primary value (no offsets applied).

NOTE: All offset values are referenced to the primary value (not the previous offset).

Using an External Input

The readout supports using an external pushbutton, footswitch, etc to trigger a regular display function.

First, determine which function should be mapped to an external input. Then use the programming menu to set parameter Pr35 accordingly:

Programming Parameter Pr35 Setting:	Function that will be performed:
0	None
1	Send function
2	Datum function
3	Offset function
4	Units mode changes
5	Absolute/incremental mode

Notes:

- Use of an external input requires a connection to the I/O pin on the green terminal strip.
- The readout can only use Input or Output at any given moment; features are mutually exclusive.
- **DO NOT APPLY VOLTAGE TO THE INPUT CONNECTOR. It should only be switched from OPEN to GROUND.**

Programming Mode (customizing the readout features)

Many functions of this digital readout are user programmable and may need to be configured to optimize operation.

Resetting All Parameters

Resetting all parameters is not necessary if you wish to customize your system.

Caution: This step is not reversible. If you have purchased a complete product (turnkey gage, stop and fence system, etc.), some parameter settings differ from factory values. *(Special parameter settings for your product are detailed inside the front cover of the original user manual.)*

To reset all parameters to the FACTORY defaults:

1. Turn the readout power off with a quick press of the ON/OFF key.
2. Open the readout case and ensure the PGM ENABLE jumper connects pins 1 and 2. (This jumper is just to left of the negative battery terminal.)
3. *Press and Hold* the **ON/OFF** and **UNITS** keys for 20 seconds.

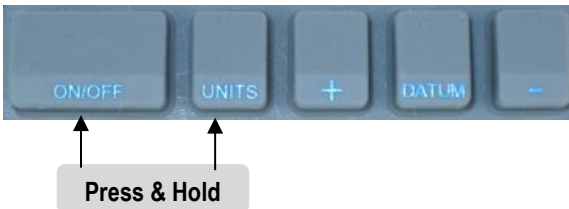

During these 20 seconds, the readout will:

1. Perform a full LCD segment test.
2. **Reset all programming parameters to factory default values.**
3. Display the firmware version of the digital readout.

After the firmware version displays, the reset is complete, and the keys may be released. Be sure to program critical values before putting readout into service.

How to Enter Programming Mode

Before making changes, open the readout case and verify the programming menu is accessible. The jumper to the left of the battery has three pins. Ensure pins 1 and 2 are connected with a shunt before proceeding. (After making changes, you can move the shunt to pins 2 and 3 to prevent further programming changes.)

Note: The programming menu uses the active measurement units when it is started. If you prefer to configure the readout in inches, be sure the screen is showing measurements in INCHES before these steps.

To start the programming menu, turn on the readout.

1. Press and hold the UNITS key.
2. Quickly press and release DATUM key. You will see **PG on**, then **Pr1**.
3. Release the UNITS key.
4. After a moment, the value for Pr1 will display.

How to Navigate and Use the Programming Mode:

To move up the parameter list:

Momentarily press the **UNITS** key to move up through the Programming Parameter list. After each press of the **UNITS** key, the readout will display the parameter number, then the currently programmed value.

To move down the parameter list:

Press and Hold the **ON/OFF** key, then *Momentarily* press the **UNITS** key to move backward through the parameter list.

To Increase a parameter value:

Momentarily press the **plus (+)** key while the parameter value is displayed.

To Decrease a parameter value:

Momentarily press the **minus (-)** key while the parameter value is displayed.

To reset a parameter value to the Factory setting:

Momentarily press the **DATUM** key while the parameter value is displayed.

How to Exit Programming Mode

1. *Press and hold* the **UNITS** key.
2. *Momentarily* press the **DATUM** key.
3. The LCD will briefly display: **PG oFF** (Programming Off).
4. Release both keys.

NOTE: The readout will automatically exit programming mode after 60 seconds without key activity.

Programming Parameters Details

Values in brackets [] represent the range of possible values available for that parameter.

Pr1 – Datum [0 to ± 999.999in]

The value that will be shown on the display when the **DATUM** key is pressed during normal operation.

Default Value= 0.000 inches

Pr2 – Reading Direction [0 or 1]

This parameter controls the direction displayed on the readout when the measuring system is moved. If the displayed value gets larger and it should be getting smaller, change this value (true for POSITIVE numbers only).

Default Value = 0

Pr3 – Programming LOCK..... [0 or 1]

In addition to the key combination on page 8, this parameter also locks the keypad (disables +, - and **DATUM** keys).

Default Value = 0

Pr 3 Setting	Key Action
0	+, - and Datum keys respond normally
1	+, - and Datum keys are locked

Pr4 – Resolution [1, 2, 3 or 4]

This parameter sets the number of decimal places displayed on the readout.

Default Value = 3

Pr 4 Setting	Resolution inches	Resolution inches
1	X.X	X.X
2	X.XX	X.XX
3	X.XXX	X.XX
4	X.XXXX	X.XX

Pr5 – Movement to Wake Readout [0.004 to .400 inches]

This parameter defines how far the system must move to automatically turn the screen back on.

Default Value = 0.004 inches

Pr6 – Fractional Rounding [0 or 1]

This parameter is used to control how fractions round up or down

Default Value = 0

Pr 6 Setting	Fractions will
0	Round down
1	Round up

Pr7 – 4th decimal place in inches----- [0 or 1]

At its core, the system works in millimeters. When converting to decimal inches, and set to display 4 places, choose how the fourth place will appear.

Default Value = 0

Pr 7 Setting	4 th decimal place will
0	Display converted value from mm
1	Show only a 0 or 5

Pr11 – Available Units [0 to 6]

This parameter controls which measurement units are available when the UNITS key is pressed.

Default Value = 0

Pr 11 Setting	Displayable Units
0	All inch units and millimeters
1	Millimeters only
2	Decimal inches and millimeters
3	Decimal inches and centimeters
4	All inch units and centimeters
5	Centimeters only
6	Decimal inches only

Pr12 – Readout Auto-Off Time [0 to 240]

This parameter changes the number of minutes before the display turns off to conserve battery power. When this parameter is set to 0, the readout will not automatically power off.

Default Value = 15 (minutes)

Pr13 – Primary Linear Compensation [0.00001 to 9.99999]

This parameter applies a linear multiplier to the input value from the encoder. This multiplier is processed BEFORE offset values are applied.

Default Value = 1.00000

Pr14 – Encoder type [0 or 1]

This parameter sets the features available for incremental or absolute technology type encoders.

Default Value = 1

Pr 14 Setting	Technology Supported
0	Incremental scales/encoders
1	Absolute series scales/encoders

Pr15 – LCD Contrast**[1- 31]**

This parameter sets the LCD contrast value. (Higher number are better for direct viewing of the LCD.)

Default Value = 27**Pr16 – Secondary Linear Compensation [0.00001 to 9.99999]**

This parameter applies a linear multiplier to the corrected value (after all compensation functions are performed). This multiplier is also processed BEFORE offset values are applied.

Default Value = 1.00000**Pr17 – Enable Angle Measurement [0, 1, 2]**

This parameter applies a mathematical formula that converts linear motion of an encoder to angular measurement over a small range of angles.

Default Value = 0

Pr 17 Setting	Angle mode enabled? Resolution inches
0	Measure length, not angles
1	Measure angles from 90 degrees at center (range is 85 to 95 degrees)
2	Measure angles from 0 degrees at center (range is -5 to +5 degrees)

Pr18 –Angle Pivot Distance [0.500 to 5.000 inches]

This parameter defines how far the linear encoder used is from the center of a pivot/bearing.

Default Value = 3.500 inches**Pr22 – ABS/INC Key Operation [0 or 1]**

This parameter has no effect with this readout model.

Default Value = 0**Pr23 – ABS/INC and SEND key operation..... [0 to 3]**

This parameter has no effect with this readout model.

Default Value = 3**Pr24 – Advanced Functions [0 to 4]**

This parameter has no effect with this readout model.

Default Value = 0**Pr25 – Go/NoGo targets [0 to 32]**

This parameter has no effect with this readout model.

Default Value = 0

Pr26 – Monitor/drift Tolerance**[.001 to 120 inches]**

This parameter has no effect with this readout model.

Default Value = .010 inches**Pr27 – Upper & Lower Limits****[0 or 1]**

This parameter turns on the limits function. (Be sure to set Pr28 to the lower limit & Pr29 to the upper limit).

Default Value = 0

Pr 27 Setting	Upper/Lower Limits Function
0	Function disabled
1	Function enabled

Pr28 – Lower Limit Value**..... [0 to ± 999.999in]**

This value sets the lower limit of Upper/Lower Limits function.

Default Value = 0.000 inches**Pr29 – Upper Limit Value**.....**..... [0 to ± 999.999in]**

This value sets the upper limit of Upper/Lower Limits function.

Default Value = 5.000 inches**Pr30 – Offset Addition****[0 to 4]**

This parameter sets how many offsets are available for the offset additions.

Note: Pr31, Pr32, Pr33, and Pr34 set the value of the offsets used.

Default Value = 0

Pr30 Setting	Offsets Enabled
0	None
1	Offset 1 Enabled
2	Offsets 1 & 2 Enabled
3	Offsets 1, 2 & 3 Enabled
4	Offsets 1, 2, 3 & 4 Enabled

Pr31 – Offset 1**[0 to ± 999.999in]**

This value is added to the current measurement when Offset Addition is enabled and the external pushbutton is pressed.

Default Value = .500 inches**Pr32 – Offset 2****... [0 to ± 999.999in]**

This value is added to the current measurement when Offset Addition is enabled and the external pushbutton is pressed.

Default Value = 2.000 inches

Pr33 – Offset 3 [0 to ± 999.999in]

This value is added to the current measurement when Offset Addition is enabled and the external pushbutton is pressed.

Default Value = 3.000 inches

Pr34 – Offset 4 [0 to ± 999.999in]

This value is added to the current measurement when Offset Addition is enabled and the external pushbutton is pressed.

Default Value = 3.000 inches

Pr35 – External Function Mapping..... [0 to 5]

This parameter maps the function that is performed when an external INPUT signal is sent.

Default Value = 0

Pr35 Setting:	Function that will be performed:
0	None
1	Send function
2	Datum function
3	Offset function
4	Units mode changes
5	ABS/INC mode change

Pr36 – No function at this time

Pr37 –Output Polarity [0 or 1]

This sets the normal state of the programmable output (when **not** activated)

Default Value = 0

Pr 37 Setting	Output Polarity
0	Normally Open (NO)
1	Normally Closed (NC)

Pr38 –Output Function [0 to 3]

Selects the function that the programmable OUTPUT works with.

Default Value = 0

Value of Pr 38	Function
0	No Operation
1	Monitor (Drift) Operation
2	Upper/Lower Limits
3	Go/No Go

Locking out access to the programming menu

After changes are made to the programming menu, access can be blocked by changing the position of a jumper on the circuit board.

Open the readout case and locate the jumper JP1. There are three copper pins to above the input connector. Two of these pins are connected with a shunt. To disable the programming menu, connect center and upper pins.

If access to the programming menu is needed later, open the case and move the jumper to center and lower pins.

Error & Alert Messages

Message	What it means
<i>F Err</i>	The readout is attempting to display a fractional value larger than 399 63/64ths
<i>no Enc</i>	There is not an encoder connected to the readout, or the connected encoder has a fault.
<i>no PoS</i>	The readout has not been calibrated yet, or when an inductive type encoder is connected after power/signal failure. This message indicates that the displayed position may not be valid.
<i>DISABL</i>	Displays if the ABS or SEND keys are pressed but their functions are disabled in programming.
<i>SEND</i>	The SEND function was activated.
<i>LOCK</i>	The keypad is LOCKed, but an attempt was made to change the calibration. Unlock the keypad to fix this, see page 8.
<i>P LOCK</i>	The keypad is LOCKed, but an attempt was made to change the calibration. Change programming parameter Pr3 to fix this, see pages 17-22.
<i>no oFF</i>	Offsets are disabled, but an attempt was made to apply an offset value.
<i>MON</i>	Monitor mode is turned on, and the system is out of the allowable drift tolerance.
<i>No Co</i>	Non-linear compensation is enabled, but there is no look-up data for the displayed ABSOLUTE MODE measurement.
<i>UNDEF</i>	Shows when F3 is pressed while in Non-linear calibration mode and no points are currently stored. Also displays when F4 is pressed and no points are currently stored.
<i>Co x</i>	A compensation point was stored to memory.
<i>BAD PT</i>	The displayed value is not close enough to the expected compensation value.
<i>CD x</i>	The previously entered compensation point was deleted.
<i>Co END</i>	Compensation entry has been completed.
<i>Hi LMT</i>	Limits mode is turned on, and an upper limit has been exceeded.
<i>Lo LMT</i>	Limits mode is turned on, and a lower limit has been exceeded.
<i>RESET</i>	The programming parameters were reset to factory defaults.
<i>No PGM</i>	Access to the programming menu was attempted, but it is currently locked out (see pages 17-22).

Accessories

Switching power supply	
Part number 550-2003-001. Provides 15VDC power to the readout.	



Popular ProScale Products

ProStop is a complete Digital Stop and Fence System for miter and chop saws. It includes an aluminum Fence, a Flip-Stop with fine adjust, double locking mechanism, and Quick-Sets. Many add-on plates available too!



ProPanel is a GIANT DIGITAL CALIPER used to make inside, outside, diagonal, hole-edge and hole-hole dimensional measurements.

This is a rugged linear measuring tool designed to make "on the manufacturing floor" measurements.



ProKit 590 is an ideal foundation for a 'build-it-yourself' dimensional measuring system. ProKit 590 is available in measuring lengths up to 190 inches (4.8m). SPC output comes standard. Wireless data transmitter is available.



ProTable-SA is a self-contained, single axis measuring table/QC station. Leg sets and casters make this product easy to move around the manufacturing floor. Temperature compensation and non-linear error correction are built into the readout. Systems are available up to 24 ft. long. Accuracy within +/- .003 inches over the entire range. SPC output and temperature compensation are included. Custom configurations are available in one or two-axis versions.



ProTable-CAB is a two-axis measuring system designed for quick and affordable length and width measurements of cabinet doors or other panel type products. Can be built with angle and out-of-square measurements too.



Thank you for choosing a ProScale Product,

IT WAS PROUDLY MADE IN THE USA



Accurate Technology, Inc.

270 Rutledge Rd. Unit E

Fletcher, NC 28732 USA

1-828-654-7920

www.proscale.com