

ENCODER:  
120 INCH CABLE IS STANDARD\*

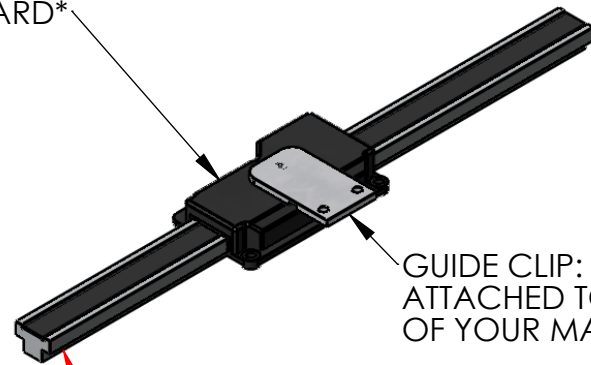

GUIDE CLIP:  
ATTACHED TO MOVING PART  
OF YOUR MACHINE

SCALE:  
MOUNTED TO FIXED PART OF YOUR MACHINE  
-THRU HOLES ARE OPTIONAL FOR EACH END OR  
-BLIND HOLES OPTIONAL ALONG LENGTH

STOCK MEASURING LENGTHS:  
24, 60, 96, 120 INCHES  
(PHYSICAL LENGTH IS 4 INCHES LONGER)

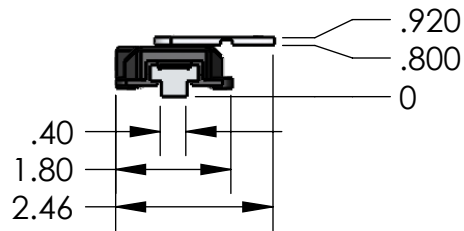
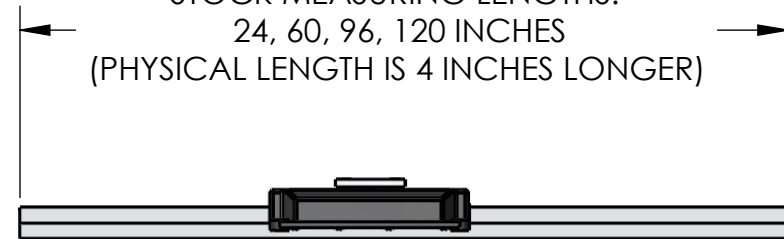

\*ENCODERS ARE STOCKED WITH:  
12, 24, AND 120 INCH CABLES. THE  
MODEL 390 IS SUPPLIED WITH A 120 INCH  
CABLE IF NOSPECIFICATION IS MADE.

**PROPRIETARY AND CONFIDENTIAL**  
THE INFORMATION CONTAINED IN THIS  
DRAWING IS THE SOLE PROPERTY OF  
ACCURATE TECHNOLOGY, INC. ANY  
REPRODUCTION IN PART OR AS A WHOLE  
WITHOUT THE WRITTEN PERMISSION OF  
ACCURATE TECHNOLOGY IS  
PROHIBITED.

UNLESS OTHERWISE SPECIFIED:

DIMENSIONS ARE IN INCHES  
TOLERANCES:  
ANGULAR: MACH ±1 BEND ±2  
ONE PLACE DECIMAL ±0.050  
TWO PLACE DECIMAL ±0.020  
THREE PLACE DECIMAL ±0.005

INTERPRET GEOMETRIC  
TOLERANCING PER:

MATERIAL

-

FINISH

-

DO NOT SCALE DRAWING

NAME DATE

DRAWN MF 1/24/2011

CHECKED

ENG APPR.

MFG APPR.

Q.A.

COMMENTS:

ACCURATE TECHNOLOGY INC

TITLE:

ProScale Model 390

SIZE DWG. NO.

**A** Installation Dimensions

REV

**A**

SCALE: 1:3 WEIGHT:

SHEET 1 OF 1