

BATTERY POWERED READOUT HAS SPC OUTPUT AND BUILT-IN THERMAL MONITOR/CORRECTION

GROUND & PLATED TOOL STEEL FIXED & MOVING JAWS

LONG LIFE BALL BEARING CARRIAGE RIDES ON HARDENED STEEL RAIL

V-CHANNEL PIECES HAVE TINY GAP AT BASE TO ALLOW CHIPS/DEBRIS TO FALL OUT.

.05 TYP. JAW CLEARANCE

DIGITAL SCALE AND SENSOR ARE INSTALLED ON REAR OF SYSTEM. THEY ARE PROTECTED BY STEEL COVER.

DETAIL A  
SCALE 1 : 3

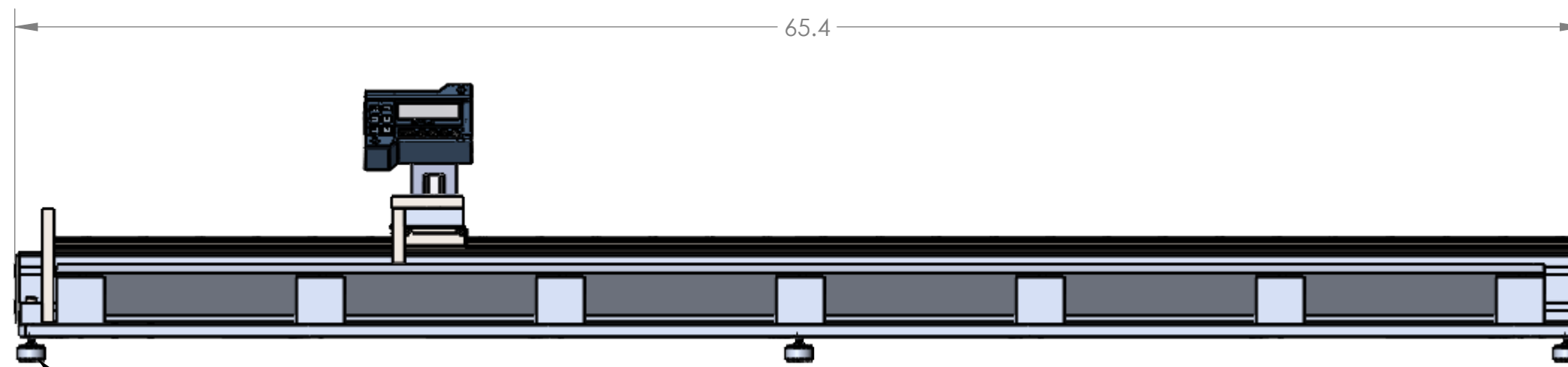
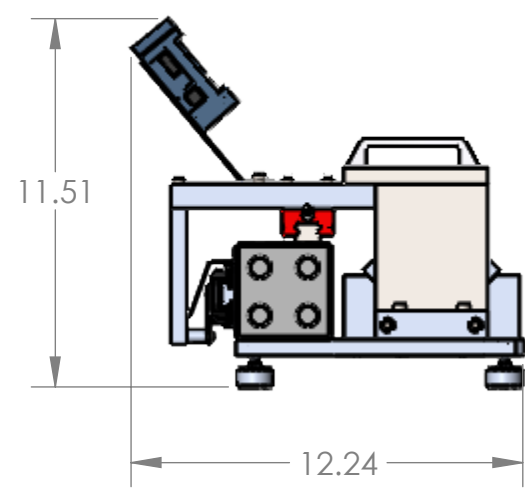

LEVELING FEET ARE INCLUDED WITH STANDARD SYSTEM. A LEG KIT (WITH OR WITHOUT CASTERS) IS ALSO AVAILABLE.

SYSTEM WITH 60" RANGE IS APPROXIMATELY 105 POUNDS WITH OPTIONS SHOWN

**PROPRIETARY AND CONFIDENTIAL**  
THE INFORMATION CONTAINED IN THIS DRAWING IS THE SOLE PROPERTY OF ACCURATE TECHNOLOGY, INC. ANY REPRODUCTION IN PART OR AS A WHOLE WITHOUT THE WRITTEN PERMISSION OF ACCURATE TECHNOLOGY, INC. IS PROHIBITED.

UNLESS OTHERWISE SPECIFIED:	NAME	DATE	ACCURATE TECHNOLOGY INC.
DIMENSIONS ARE IN INCHES	DRAWN	MF	12-7-18
TOLERANCES:	CHECKED		
ANGULAR: MACH ±1 BEND ±2	ENG APPR.		
ONE PLACE DECIMAL ±0.050	MFG APPR.		
TWO PLACE DECIMAL ±0.020	Q.A.		
THREE PLACE DECIMAL ±0.005	COMMENTS:		
INTERPRET GEOMETRIC TOLERANCING PER:			
MATERIAL ASST			
FINISH ASST			
DO NOT SCALE DRAWING			
TITLE:			901-5070-060
SIZE	DWG. NO.	REV	
C	ProTable-TUBE-60 (benchtop)	C	
SCALE: 1:6	WEIGHT:		SHEET 1 OF 1