

# Accurate

TECHNOLOGY INC.

*Linear Digital Measuring Systems*



## DigiStop

(Systems with Firmware version 4)

---

## WARRANTY

Accurate Technology, Inc. warrants the ProScale products against defective parts and workmanship for 3 years commencing from the date of original purchase. Upon notification of a defect, Accurate Technology, Inc., shall have the option to repair or replace any defective part. Such services shall be the customer's sole and exclusive remedy. Expenses incidental to repair, maintenance, or replacement under warranty, including those for labor and material, shall be borne by Accurate Technology, Inc. (Including freight or transportation charges during the first 30 days).

Except as expressly provided in this warranty, Accurate Technology, Inc. does not make any warranties with respect to the product, either expressed or implied, including implied warranties of merchantability or fitness for a particular purpose, except as expressly provided in this agreement.

Accurate Technology, Inc. shall not be liable for any special, incidental, or consequential damages or for loss, damage or expense directly or indirectly arising from the customer's use of or inability to use the equipment either separately or in combination with other equipment, or for personal injury or loss or destruction of other property, or from any other cause.

To request repair work, (either warranty qualified parts or not) contact Accurate Technology, Inc. directly by phone or e-mail. A Returned Merchandise Authorization (RMA) number is required before returning a product for repair.

### **SAFETY WARNING**

**Before installing DigiStop on any machinery:  
Turn off machine and LOCK-OUT POWER.**

---

**READOUT SERIAL #**

\_\_\_\_\_

**DATE OF MANUFACTURE**

\_\_\_\_\_

**FACTORY CONFIGURED PARAMETERS WHICH ARE SPECIFIC TO THIS PRODUCT:**

<b>Programming control</b>	<b>Value</b>
PARAMETER 2 (Reading direction)	1 (left-infeed configuration)
PARAMETER 11 (Available display units)	0 (all units)
PARAMETER 13 (Linear Correction Value)	
PARAMETER 14 (ProScale Technology)	0 (Inductive)
PARAMETER 24 (Monitor Mode)	1 (enabled)

See [www.proscale.com/700-1600-240](http://www.proscale.com/700-1600-240) for more details about these settings.

---

**TABLE OF CONTENTS**

**INTRODUCTION** ..... 5

**SPECIFICATIONS** ..... 6

**DIGISTOP PARTS IDENTIFICATION** ..... 7

**DIGISTOP INSTALLATION** ..... 8

    MOUNT THE FENCE & ELECTRONIC SCALE ..... 8

    INSTALL THE SLIDING STOP ASSEMBLY ..... 10

    INITIAL CALIBRATION ..... 11

    DIGITAL STOP OPERATION ..... 12

    CUSTOMIZING THE READOUT’S OPERATION ..... 12

**MAINTENANCE** ..... 13

**BATTERY REPLACEMENT** ..... 13

**KEY FUNCTIONS** ..... 14

**WHAT DO ALL THE SYMBOLS MEAN?**..... 15

**PROGRAMMING MODE** ..... 17

**COMMON ERRORS** ..... 18

**FREQUENTLY ASKED QUESTIONS** ..... 19

---

## Introduction

DigiStop is a general-purpose Digital Stop & Fence System. It is ideal for use on Miter saws, Chop Saws, Radial Arm Saws, band saws, drill presses, or any other application where a moveable stop along a fixed back fence is desired. It has been designed using high quality extruded and machined parts to provide the best accuracy and repeatability.

DigiStop should NOT be used as a length checking system for Quality Control; its design is not well suited for that purpose.

This manual includes installation and operation information for DigiStop systems built with a BASIC Readout with operating firmware version of 4.000 and higher.

(The firmware version is displayed when the readout is powered on using the ON/OFF key.)

---

## Specifications

Positioning Range <sup>1</sup> :	Up to 234 inches in a single section
Accuracy <sup>2</sup> :	+/- 0.010 inches (0.25 mm)
Resolution	Inches: 1, 2, 3, or 4 decimal places Millimeters: 1 or 2 decimal places Centimeters: 1, 2, or 3 decimal places Fractions: 1/16 <sup>ths</sup> , 1/32 <sup>nds</sup> , or 1/64 <sup>ths</sup>
Repeatability:	.001in, or .01mm, or .001cm
Operating Temp:	32 to 110°F (0 to 42 C)
Max. Slew Rate:	80 inches/sec. (2000mm/sec)
Power:	1 CR123, 3V Lithium battery (or equivalent)

<sup>1</sup> Positioning range is approximately 4 inches *shorter* than the PHYSICAL length of the aluminum fence extrusion.

<sup>2</sup> Maximum observed error over the entire measuring range after linear correction factor is used.

---

# DigiStop Parts Identification

## Electronic Scale

DigiStop systems use Inductive Series 2 Incremental electronic scales. The electronic scale includes 2.00 inch x 0.50 inch aluminum extrusion with repeating sections of black circuit board material, as shown below.



## Encoder/Sensor

Encoders for DigiStop have black housings and 12 inch cable lengths.



## Digital Readout

DigiStop can operate with any of several different Digital Readouts, but is supplied with a BASIC readout unless otherwise specified. It is powered by (1) CR123 battery.



### New for this version readout:

A battery indicator appears on the left side of the LCD screen. There are 3 tiers of battery shown, which represent the voltage level of the battery. When only one tier is left, a new battery should be prepared for installation.



## Sliding Stop Assembly

A sliding stop with lock handle on top. This assembly includes the readout and the encoder.

## Fence

The extruded aluminum fence provides back support for the material to be cut, and is a guideway for the Sliding Stop Assembly to read the electronic scale.



## Cap

A press-in plastic cap is provided for covering the outboard end of the fence extrusion. Use of this cap is optional.

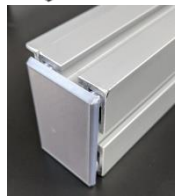

---

# DIGISTOP INSTALLATION

## Mount the Fence & Electronic Scale

These steps detail installation onto a table, on the left side of a chop saw. The steps may change based on your machine type, workbench setup, or working space. If you have questions, please consult our factory for assistance.

1. Place the fence profile next to the saw. The electronic scale will be facing AWAY from the operator, and flush with the TOP PLANE of the fence, as shown here:

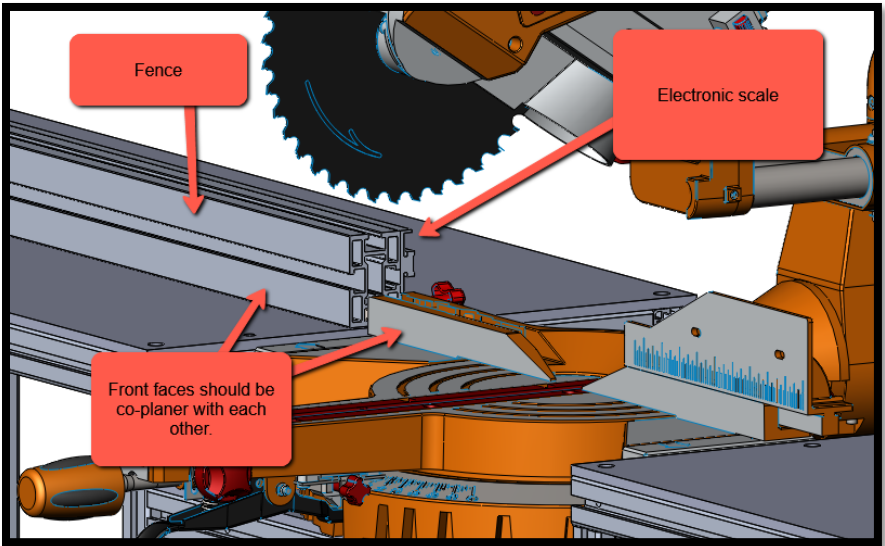

2. Align the fence so it is co-planer with any existing fences on the saw. (If there is not an existing fence, install the fence so it is perpendicular to the saw blade.
3. Mark a line on the table/bench, along the front edge of the Fence.
4. Remove the Fence assembly and mark a second line 7/8 inch (22mm) behind the first line (this is the CENTERLINE of the Fence).
5. Drill mounting holes (at least 2) into the tabletop along the centerline of the Fence. The holes should be 7/16" diameter (11mm) or slightly larger.



- 
6. Insert the supplied 10mm bolts through the holes in the table, as shown below. Install a washer and a hex nut onto each bolt, 1 or 2 threads deep at this time.

Note: The supplied 10mm bolts will mount DigiStop to any bench/table up to 2.50 (63mm) thickness.

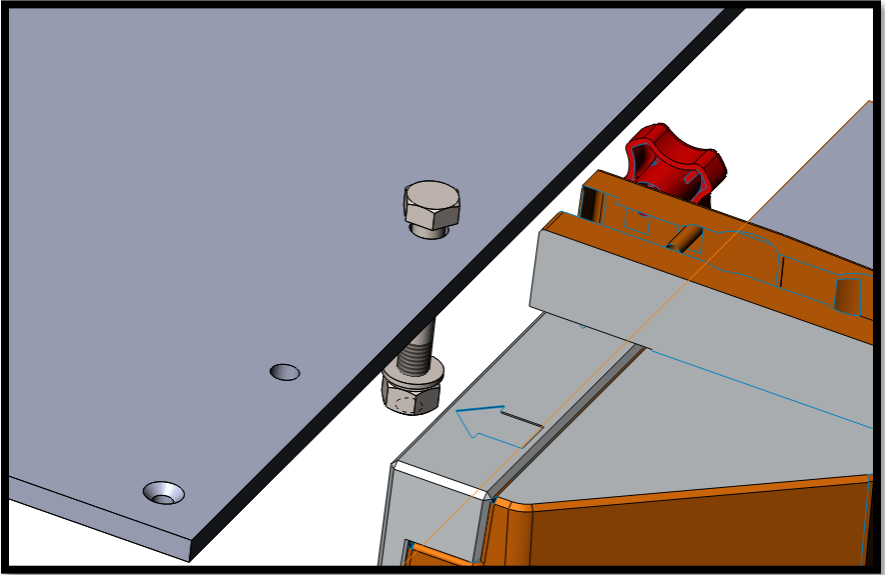

7. Slide the Fence over the M10 bolts, capturing the top of each bolt in the bottom T-slot of the fence profile. After the Fence is in place, and alignment is checked with the saw, tighten all nuts using a 16mm socket/wrench, or with a crescent wrench.

**Alternative installation:** If the fence cannot be slipped over the M10 bolt heads, you may elect to slide the M10 bolts into the bottom of the fence first. Then drop the entire assembly into place, guiding the M10 bolts into the benchtop holes:

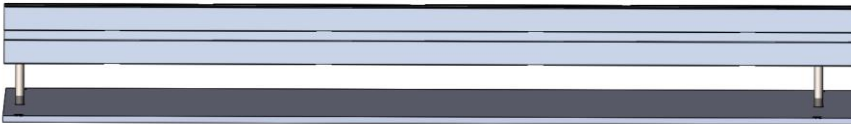

---

## Install the Sliding Stop Assembly

1. Slide the encoder/sensor onto the electronic scale.

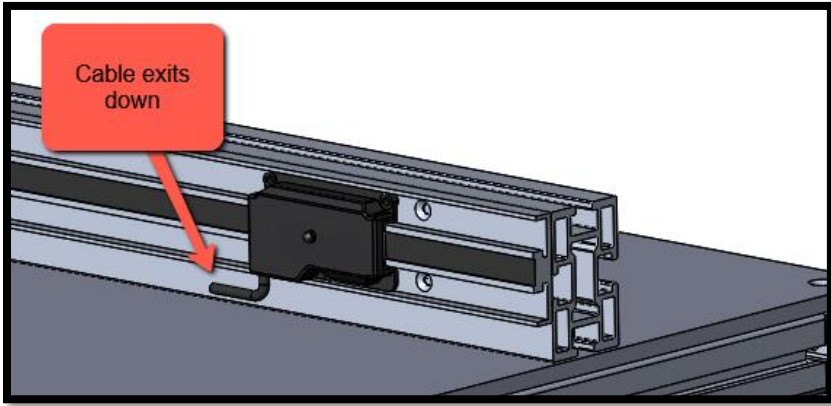

2. Attach the readout bracket to the back of the sliding stop assembly. Tighten bolts.
3. Attach the Guide Clip to the back of the sliding stop assembly. Tighten screws. **NOTE: The slot in guide clip faces inward.**
4. Loosen the Stop Assembly lock handle and slide the assembly onto the fence. Be sure to guide the lock nut into the upper T-slot in the fence.
5. Slide the encoder along the electronic scale and position it under the Guide Clip on the Stop Assembly. The post on the top of the Encoder should snap into the slot on the inside of the Guide Clip.
6. Plug the Encoder into the Digital Readout.
7. Press the DATUM key one time. The displayed value will zero out.
8. Move the stop assembly from right to left. Does the measurement increase as you expect? If yes, proceed to next step. If no, either reverse the encoder (so cable exits up), or change Pr2 in the programming menu of the Digital Readout (consult factory for assistance).
9. A plastic end cap is provided for the outboard end of the fence. (Use of this is optional.) To install, hold the cap at the outboard end of the fence profile, and use a rubber mallet to insert into the extrusion.

---

## Initial Calibration

1. Check to be sure installation of all parts is complete, all fasteners are secure, and the Encoder is plugged into the Digital Readout.
2. Move the sliding stop close to the blade. Lock the stop in place.
3. Cut a sample part to an arbitrary length using the DigiStop.
4. Measure the length of the cut part with the most precise measuring tool available (i.e. digital calipers).
5. Without moving the Sliding Stop, press the Datum key to zero the measurement.
6. Use the PLUS key (or MINUS key) to set the displayed reading equal to the measurement obtained in Step 4.  
*Note: You can make the reading change faster by holding the PLUS or MINUS key down. (The rate of change increases each 2.5 seconds.)*
7. When the correct reading is reached, lock the keypad. This prevents accidental loss of calibration if a key is accidentally pressed:
  - a. Press and hold the ON/OFF key.
  - b. Quickly press and release the UNITS key.
  - c. A **LOCK** symbol will appear on the screen, and the PLUS, DATUM, and MINUS keys are deactivated.

Recalibration should be done:

- When blade kerf changes, (i.e. after changing the saw blade).
- When the battery in the readout is replaced.
- When the accessory plate is changed. (*In some cases, using OFFSETS can be used for this instead.*)

---

## Digital Stop Operation

See page 7 for part identification.

1. Unlock/loosen locking knob.
2. Move the Sliding Stop to the approximate position that is desired.
3. Tighten the locking knob.
4. Position your material against the stop face and complete cut.

## Customizing the readout's operation

You may wish to set some initial parameters for your DigiStop application to optimize its use. Commonly changed items include:

### **Measurement Units**

The measurement units that are displayed (inch, mm, cm) are selected with each quick press on the UNITS Key.

### **Resolution**

The resolution of the displayed units is programmed using Programming Parameter Pr4.

### **Fractions Operation**

By default, fractions are rounded DOWN, but this can be changed using parameter Pr6.

### **Auto-Off Timer**

The readout will automatically power off to save power after 15 minutes of inactivity. This timer can be changed using Programming Parameter Pr12. *Similarly, the amount of motion needed to wake up the readout is configured using parameter Pr5.*

There are several dozen other customizations that can be made to the system, see page 17.

---

## Maintenance

DigiStop will operate in a dry environment with non-conductive debris such as sawdust, plastic, metal dust, and small amounts of water splash with no adverse effects. The system should be cleaned of excess debris when necessary to prevent premature damage to the electronic scale and encoder/sensor. The digital readout should be cleaned periodically with compressed air to remove any dust on the lens and keys. If the Sliding Stop becomes difficult to move, be sure the upper T-slot is clear of debris.

Each 6 months:

- All mounting fasteners should be checked for tightness.
- Apply wax or dry lubricant to the fine adjustment shaft.

Every 2 years:

- Replace the Guide Clip.
- Replace the battery in the readout.

Every 5 years:

- Replace the small nylon buttons that the Sliding Stop rides on.
- Replace the 2 lock nuts.

*Timing is based on 4 hours of use each day in a reasonably clean environment. Adjust schedule as necessary to suit your use.*

## Battery Replacement

When the battery in the digital readout needs to be replaced, the battery icon will only show one bar, or you will see a “**B FAIL**” message on the screen. Remove the screws in the upper right and lower left corners of the readout. Pull the cover off. Remove the old battery. Install a new CR123 (or equivalent) battery noting the proper orientation. Replace the cover and screws.

**Tip: Be careful to avoid touching parts of the circuit board not related to the battery.**



## Key functions



What happens on a **QUICK PRESS** of each key?

Key	Action
ON/OFF	The readout turns on or off.
UNITS	The units change. <i>Note: Available units can be restricted with custom programming settings.</i>
PLUS	The displayed value is increased one unit.
DATUM	The displayed value is set to the programmed datum value. <i>Note: This value is zero by default, but it can be customized to be any value.</i>
MINUS	The displayed value is decreased one unit.

What happens if a **KEY IS HELD DOWN?**

Key	Action
ON/OFF	Nothing
UNITS	Nothing
PLUS	The displayed value increases faster each 2 seconds.
DATUM	After 4 seconds, the battery voltage is displayed. After 7 seconds, the readout's temperature is displayed.
MINUS	The displayed value decreases faster each 2 seconds.

### Key Combinations:

For these actions, **press and hold the first key**, then quickly **press and release** the second key. (*This action is the same as making a capital letter on a computer; the first key acts like SHIFT.*)

Press and hold	Then quickly press and release	Action
ON/OFF	UNITS	LOCK (or unlock) the keypad.
ON/OFF	DATUM	Enters or exits the programming mode.*
UNITS	PLUS	Adds one segment to displayed value. ( <i>Models 150/250 only.</i> )
UNITS	MINUS	Adds one segment to displayed value. ( <i>Models 150/250 only.</i> )

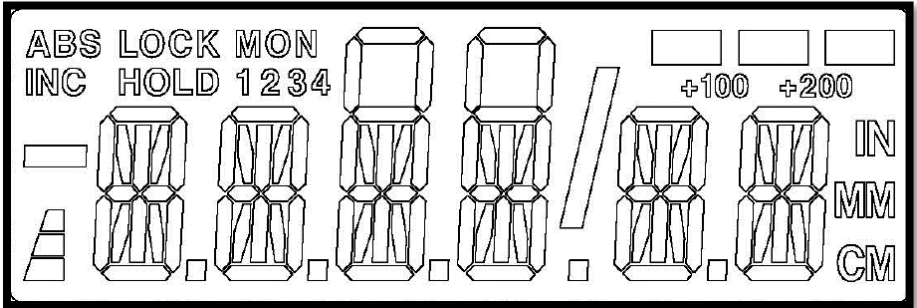

\*Requires programming jumper to be in position 1; see image on page 13.

## What do all the Symbols mean?



Symbol	Meaning
ABS	The digital readout is operating in Absolute measurement mode.
INC	<i>This feature not compatible with DigiStop.</i>
LOCK	The readout is in LOCK mode. This prevents loss of calibration if PLUS, MINUS, or DATUM keys are pressed. See page 14 for key combination to turn this off.
HOLD	<i>This feature not compatible with DigiStop.</i>
MON	<i>This feature not compatible with DigiStop.</i>
1 2 3 4	<i>This feature not compatible with DigiStop.</i>
	These are used with the 16 <sup>th</sup> and 32 <sup>nd</sup> fractional inch modes. Each bar represents an extra 1/64 <sup>th</sup> long/heavy on the dimension.

**Symbols (continued):**

<p><b>+100    +200</b></p>	<p>When using fractions over 99 inches, one (or both) of these will light to show a value over 100 inches. For example: measurement is 205 5/16. The readout will show <b>5 5/16</b> and turn on the <b>+200</b> indicator.</p>
	<p>Minus sign. Turns on when a negative value is displayed.</p>
	<p>Battery level indicator. When all 3 bars are lit, the battery is good. When only bottom bar is lit, a new battery is needed soon.</p>
	<p>Vinculum – used in fractions mode to separate numerator from denominator.</p>
<p>IN MM CM</p>	<p>Units indicator. IN is for INCHES or fractions. MM for millimeters. CM for centimeters. (Press UNITS key to change.)</p>



---

## Programming Mode

Many features of the readout can be customized (plus additional tools can be enabled) using the programming menu.

Parameter number	What it does	Default value
Pr1	Sets the DATUM key's value.	0.000
Pr2	0 = default reading direction 1 = reversed reading direction	0
Pr3	0 = +, - and DATUM keys are operative. 1 = These keys are disabled (LOCK).	0
Pr4	The resolution for decimal readings.	3
Pr5	Motion needed to wake up the readout.	0.004 inches
Pr6	Do fractions round up or down?	0 (round down)
Pr7	Resolution of 4 <sup>th</sup> decimal place (inches)	1 (.0005" resolution)
Pr11	Controls available UNITS modes.	0 (All units)
Pr12	Auto-off timer (in minutes)	15
Pr13	Linear multiplier	1.00000
Pr14	Encoder compatibility	1 (Absolute scale)
Pr15	LCD contrast adjustment	27
Pr16	Final linear multiplier	1.00000
Pr22	ABS/INC key operation	0 (2 seconds)
Pr23	Supplemental keys enabled?	3 (All enabled)
Pr24	Monitor/hold, Go/NoGo features	0 (Disabled)
Pr25	Go/NoGo values to save	0 (None)
Pr26	Drift Monitor tolerance	.01 inches
Pr27	Limits modes used	0 (Not used)
Pr28	Lower limit value	0.000
Pr29	Upper limit value	5.000 inches
Pr30	Offset additions to use	0 (None)
Pr31	First offset value	0.5000 inches
Pr32	Second offset value	2.0000 inches
Pr33	Third offset value	3.0000 inches
Pr34	Fourth offset value	3.0000 inches
Pr35	External input operation mapping #1	0 (No function)
Pr36	External input operation mapping #2	0 (No function)
Pr37	Polarity for Output functions	0 (Normally open)
Pr38	Output Function used	0 (None)

---

## Common Errors

The following is a list of the most common error codes and their meaning. For additional help with any error message, consult factory.

<b>Message</b>	<b>What it means</b>
<i>no Enc</i>	There is not an encoder connected to the readout, or the connected encoder has a fault.
<i>no Pos</i>	The readout has not been calibrated yet.
<i>b fail</i>	The battery in the readout needs to be replaced immediately.
<i>f fail</i>	The readout cannot display fractional values larger than 399 63/64 inches.
<i>P fail</i>	The battery in the readout needs to be replaced immediately. Check programming values after new battery is installed.
<i>LOCK</i>	The keypad is LOCKed, but an attempt was made to change the calibration. Unlock keypad to fix, see page 14.
<i>P LOCK</i>	The keypad is LOCKed, but an attempt was made to change the calibration. Change programming parameter Pr3 to fix.
<i>Reset</i>	The digital readout's parameters have just been defaulted.

---

## Frequently Asked Questions

### **What does no Enc mean?**

The Sliding Stop has been moved too fast, or  
The encoder and the readout are not communicating.  
To clear this error:

1. Be sure the encoder is on the electronic scale.
2. Unplug the encoder from the readout for five seconds.
3. Connect the encoder to the readout.

### **What does b FAIL mean?**

When the readout displays this message, it means the battery voltage has dropped to a level where reliable operation is no longer possible. Install a new battery to clear this message.

### **What does P FAIL mean?**

When the readout displays this message, it means the battery voltage has dropped to a level where reliable programming is not possible. Install a new battery to clear this message.

### **The readout does not change, or changes very little, as it moves.**

1. The readout is in the HOLD mode.
2. The linear scaling factor is set very low.
3. The encoder is not properly captured by the Guide Clip.

---

**Thank you for choosing a ProScale Product,**

**IT WAS PROUDLY MADE IN THE USA**



**Accurate Technology, Inc.**

270 Rutledge Rd. Unit E

Fletcher, NC 28732 USA

828-654-7920

[www.proscale.com](http://www.proscale.com)

**Part # 800-1070-100**

**Copyright © 2020, Accurate Technology, Inc. All rights reserved.**