

ProScale

**NEW ENHANCED FEATURES!
PLEASE SEE SECTION 4 FOR
NEW OPERATION INSTRUCTIONS**



Model 150 and Model 250

Includes Systems with the following Digital Displays:
General Purpose, General Purpose Basic,
1/4 DIN LCD, & 1/8 DIN **LED**

Accurate
TECHNOLOGY INC.
Linear Digital Measuring Systems

Warranty

Accurate Technology, Inc., warrants this product against defective parts and workmanship commencing from the date of original purchase. Upon notification of a defect, Accurate Technology, Inc., shall have the option to repair or replace any defective part. Such services shall be the customer's sole and exclusive remedy. Expenses incidental to repair, maintenance, or replacement under warranty, including those for labor and material, shall be borne by Accurate Technology, Inc. Freight or transportation charges to Accurate Technology, Inc., shall be paid by the customer.

Except as expressly provided in this warranty, Accurate Technology, Inc., does not make any warranties in respect to the product, either expressed or implied, including implied warranties of merchantability or fitness for a particular purpose, except as expressly provided in this agreement.

Accurate Technology, Inc., shall not be liable for any special, incidental, or consequential damages or for loss, damage or expense directly or indirectly arising from the customer's use of or inability to use the equipment either separately or in combination with other equipment, or for personal injury or loss or destruction of other property, or from any other cause.

To request repair work (either warranty qualified parts or not), contact Accurate Technology, Inc. directly by phone, fax, or e-mail. A Returned Merchandise Authorization (RMA) number is required before returning a product for repair.

SAFETY WARNING

Before installing ProScale products, turn off the machine and disconnect it from its power source to avoid injury.

SAFETY WARNING

Table of Contents

Section 1	General Information	5
	Introduction	5
	ProScale Terminology	5
	Scales	6
	Absolute	6
	Incremental	7
	Readheads	7
	Absolute	7
	Incremental	8
	Displays	8
	Product Specifications	9
Section 2	Model 150	10
	Installation:	10
	Calibration:	12
	Maintenance:	12
Section 3	Model 250	13
	Installation:	13
	Calibration:	15
	Maintenance:	16
Section 4	Digital Displays	17
	General Purpose Display	18
	Display Power	18
	Programming the Display	18
	Position Display Units	20
	Measuring Modes	20
	Offset Adjustment	21
	Lock Mode	21
	Display Hold Mode	21
	Position Monitor Mode	22
	Segment Offset Adjustment	22
	Sending Data to SPC device	23
	F1 /F2	23
	Jumpers	23
	Changing the Batteries	24
	Mounting the Display	24

1/4 DIN LCD Panel Mount Displays	25
Power Supply	25
Mounting the Display	25
Changing the Measurement Mode:	25
Programming the Display	26
Position Display Units	28
Measuring Modes	28
Offset Adjustment	28
Lock Mode	29
Display Hold Mode	29
Position Monitor Mode	29
Segment Offset Adjustment	29
Sending Data to SPC device	30
F1 /F2	30
Jumpers	31
1/8 DIN LED Panel Mount Displays	32
LED Display System Features	32
Keypad Functions	33
ABS and INC Operating Modes	33
Offset Locking	34
Segment Adjustment	34
Displayed Measurement Units	34
Programmable Output	34
Electrical Connections	34
System Programming	36
Programming Parameters	37
RS-485 Bus Commands	38
Section 5 Miscellaneous	39
Scales	39
Readheads	39
Frequently Asked Questions	40
Product Communication:	41
Error Codes & Factory Service	41
Abbe Error	42
Section 6 Accessories	43
ProMUX-3	43
ProMUX-4, ProMUX-8	44
Pro RF	45
Product Registration	46

Introduction

ProScale™ digital measuring systems are affordable precision electronic devices for making linear measurements with speed and accuracy. ProScale consists of a scale, a readhead (or encoder) mechanism and a digital display. It uses capacitive encoder technology, the same technology used in digital calipers.

ProScale is ideal for most measuring requirements where high – (1 µm accuracy) – is not needed. Because ProScale shows the exact measurement on its display, it eliminates the guesswork involved in reading and interpreting tape, pointer, or shaft encoder scales. It is compatible for retrofitting or as original equipment on most machinery and as a result, machine setup time can be reduced considerably, maximizing throughput on a machine.

Depending on the chosen digital display, ProScale's measurement mode can be changed to display in sixteenths, thirty-seconds, sixty-fourths, or thousandths of an inch. If accustomed to working with metric measurements, in millimeters or centimeters. In any mode, ProScale is designed to provide and maintain its accuracy for years.

ProScale is extremely rugged and durable. Unlike optical measurement systems, the accuracy of capacitive systems is not affected by sawdust or other non-conductive contaminants. Additionally, power consumption is much less than magnetic or optical measurement systems.

Because ProScale is a solid-state electronic device there's very little to wear out. The readhead and scale are designed to withstand shop dirt, dust, and other airborne contaminants, and the controls are sealed with a protective cover for long life. With normal care, ProScale will last for years.

ProScale Terminology

All ProScale systems consist of a **SCALE**, a **READHEAD**, and a digital **DISPLAY**.

The **SCALE** consists of a series of conductive patterns bonded to an aluminum extrusion. The **READHEAD** contains a computer chip, which transmits and receives signals to the scale using capacitive coupling. The received signal is used by the readhead to calculate it's position to within 0.005mm. This position data is then sent to the digital **DISPLAY**, where it can be displayed in millimeters, centimeters, inches, or sent to an external data acquisition device.

Each **SCALE** and **READHEAD** uses either incremental or absolute technology. Absolute systems use a more robust and sophisticated method to measure position, resulting in a high immunity to electrical interference and one that does not forget its position when power is removed. Because not all ProScale systems utilize the same style display, it is very important to understand exactly which components your ProScale uses. This may be determined by the pictures and descriptions on the following pages of this manual, by reviewing our web site, by the label on the packaging, or by contacting your supplier.

Scales

Absolute

An absolute system (ABS) measures its actual position by reading a pattern which is unique at any given location over its length. The maximum length of a ProScale absolute pattern is 430mm (16.932 in.). The pattern must then repeat itself.



Consider the illustration above to represent a ProScale ABS. There are three absolute patterns (each pattern is 430mm long), joined together end to end. Within each pattern the system is totally absolute. However, crossing over a pattern joint now presents the readhead with information identical to what it read in the previous pattern. At this point the system must be able to recognize that it has crossed over a pattern joint and therefore must add or subtract the value of 1 pattern offset - 430mm. In fact, each time the readhead passes over a pattern joint it must keep track of how many patterns it has passed, and in which direction. This action is accomplished by the digital display.

What does all this mean? If the readhead remains on the same absolute pattern, it can have power removed, its position changed and power restored without loss of position information. However, if power is removed and the readhead passes over a pattern joint, the transition will not be recognized. When power is restored the system knows its absolute position on the new pattern, but does not know how many patterns it has passed, or in which direction!

ProScale displays provide the operator with a method to adjust the pattern offset so the system displays the correct reading at all times without loss of accuracy. See Section 4 for information about the different displays and how to correct for pattern offsets.

All ABS scales have a “zigzag” pattern etched onto the green laminate. **Take care to not damage this etching** or remove the green coating. There should also be a pattern “break” approximately every 430mm (17in.). **Do not attempt to shorten ABS style scales; call Accurate Technology for assistance.**



Incremental

Simply stated, an Incremental system measures the distance it has traveled relative to a starting point. Incremental style scales have a repeating “bar” pattern etched onto the green laminate. Take care not to damage the etched pattern, or remove the green coating. There should be a pattern “break” approximately every 574mm (22.6in.). Incremental style scales may be shortened if needed. For more detailed instructions, see Section 5. Incremental scales are used on Accurate Technology’s ProStop, ProKit, Measuring Kits, ProCaliper, and ProPanel products.

Incremental Style Pattern

Model 150 Absolute scales should be mounted to machinery using the supplied M5 (or 10-32) machine screw and Connector Link. This Connector Link is specially designed to flex slightly if there is any mechanical binding in the readhead-to-scale mounting. The Connector Link should always be mounted in the same direction as the scale (see the diagram Section 2). **Warranty is void if the Connector Link is not used.**

Model 150 & 250 Absolute scales are designed to be mounted on machinery using M4 (or 6-32) Flathead screws. Accurate Technology provides a Guide Clip to attach the readhead to a moving part of a machine, see the diagram in Section 3 **Warranty is void if the Guide Clip is not used.**

Readheads

Absolute

“**ABS**” style readheads have “**BLACK END OF SCALE**” labels on the cover, and the wire exits from the *corner* of the housing. Extreme care must be taken not to damage the six brass “fingers” inside the readhead housing. *ABS* style readheads, used in all Model 150 and Model 250 systems, **must** be mounted on *ABS* scales with a particular orientation. Each readhead has an arrow on the label pointing in the direction of the “**BLACK END OF SCALE**” (each *ABS* style scale will have one end painted black). This relationship is very important, since the readhead will work, but produce erratic results if incorrectly installed. To insure proper operation, be sure the arrow on the readhead is pointing toward the **BLACK** end of the scale. The standard readhead has 3m (10 ft.) of cable. For special cable lengths, contact Accurate Technology, Inc.



Incremental

Incremental style readheads do *not* have labels on the cover, and the wire exits from the *center* of the housing. Care must be taken not to damage the brass “fingers” inside the readhead housing. Incremental readheads may be mounted on incremental scales with any orientation. Incremental readheads are used on Accurate Technology’s ProStop, ProKit, Measuring Kits, ProCaliper, and ProPanel products.



Displays

Refer to Section 4 - *Digital Displays* - for installation, programming and operation specific to these displays:



General Purpose LCD Display
(Replaces: Incremental, Basic, Standard,
SPC & Programmable Digital Displays – Part #'s
701-1495-00x,701-1500-00x,701-1505-00x,701-1115-00x)



1/4 DIN Panel Mount LCD Display
(Battery & 24VDC)
(Replaces earlier 1/4 DIN Part #'s 701-1525-00x, 701-1550-00x)



1/8 DIN Panel Mount LED Display
X Certified

Additional Available Displays covered in Separate Manuals:



Panel Mount Position Control Unit
24VDC Panel Mount



Dual Input Panel Mount LCD
24VDC, A+B, A-B, RS232 output

Product Specifications

Accuracy:	$\pm .165\text{mm/m}$ to $\pm .20\text{mm}$ max error from 2-6 meters $\pm .002\text{in/ft}$ to $\pm .008\text{in}$ max error from 4-20 feet
Repeatability:	.01mm or .001in
Display Range:	$\pm 9999.99\text{ mm}$; $\pm 999.999\text{ cm}$; $\pm 394.000\text{ in}$; $\pm 99\ 63/64$ (depends on display type)
Operating Temp:	0 to 51°C, 32 to 120°F
Temp Coef:	25ppm/1 °C (i.e. $\Delta .06\text{mm}$ / over 2.5m / 10° C)
Max. Slew Rate:	450 mm/sec. (18 inches/sec.)
Available Displays:	General Purpose AA battery LCD display 1/4 DIN 2D battery panel mount LCD display 1/4 DIN 24 VDC panel mount LCD display 1/8 DIN 24 VDC panel mount LED display 1/4 DIN 24 VDC panel mount position control & LCD display Dual Input 24VDC panel mount with RS232 output
Output Format:	Mitutoyo SPC format. (Selected display types)
Readhead:	3m, six-conductor cable terminated by RJ12 modular connector. To increase or decrease cable length, contact Accurate Technology. (Maximum cable length 10m)
Dimensions:	Available at www.proscale.com .
US Patents:	4420754, 4879508, 4878013, 4959615
Warranty:	Three years from date of purchase.

All ProScale products are MADE IN USA



ProScale Model 150

General Purpose system with standard measuring ranges of 250mm and 450mm.

Model 150 systems use *ABS* style scales, *ABS* style readheads, and general-purpose, panel mount, or Position Control digital displays. Neither the scale nor readhead are compatible with other Accurate Technology ProScale incremental systems.

ProScale is easy to install. By following the basics of good installation in this section, reliable, error-free operation is assured. Because ProScale can be installed on many different types and brands of equipment, all installations will be a little different. Therefore, it's the responsibility of the installer to choose the bolts, screws, or other mounting hardware that guarantee proper installation for optimum operation.

Note: If a custom kit was ordered which contains instructions for installing ProScale on a specific product, follow those instructions rather than the general instructions here.

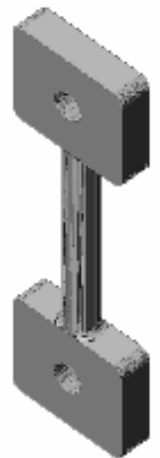

Connector Link

Installation:

1. Note the orientation of the readhead on the scale. Be sure the arrow on the readhead points towards the “**BLACK END OF SCALE**”. This orientation is critical for proper operation of ProScale. Be sure the mounting location for the readhead and scale will allow this orientation.
2. Determine an appropriate mounting location for the system. The readhead should be mounted to a **stationary** part of the machine. The scale should be mounted to the **moving** part of the machine with the connector link. Be sure to allow sufficient space to accommodate the connector link, which is used to mount the scale to the moving

part of the machine. The Display should be mounted in a location which allows for easy viewing by the machine operator. The location of the parts should also safeguard the cable from possible damage. All ProScale wiring should be kept as far away as possible from the machine's wiring and motors and dust collection systems. Avoid running the readhead wiring parallel to high voltage/current wiring.

3. Mount the readhead using three screws or bolts. It may be necessary to use washers or spacers to ensure a good mount (if the readhead is to be mounted on an uneven surface).
4. Check that the scale is properly aligned with the direction of motion of the moving part. The connector link will compensate for only a small amount of misalignment. The connector link **must** be mounted in the same direction as the scale (as in the figure below).

Note: Failure to use the connector link will void the warranty.

5. Mount one end of the connector link to the scale using an M5 (or 10-32) screw and the other end to the moving part of the machine. Check that both connections are secure; inaccurate/erratic readings may otherwise occur.
6. Plug the readhead into the display. See Section 4 regarding mounting and use of different display versions.

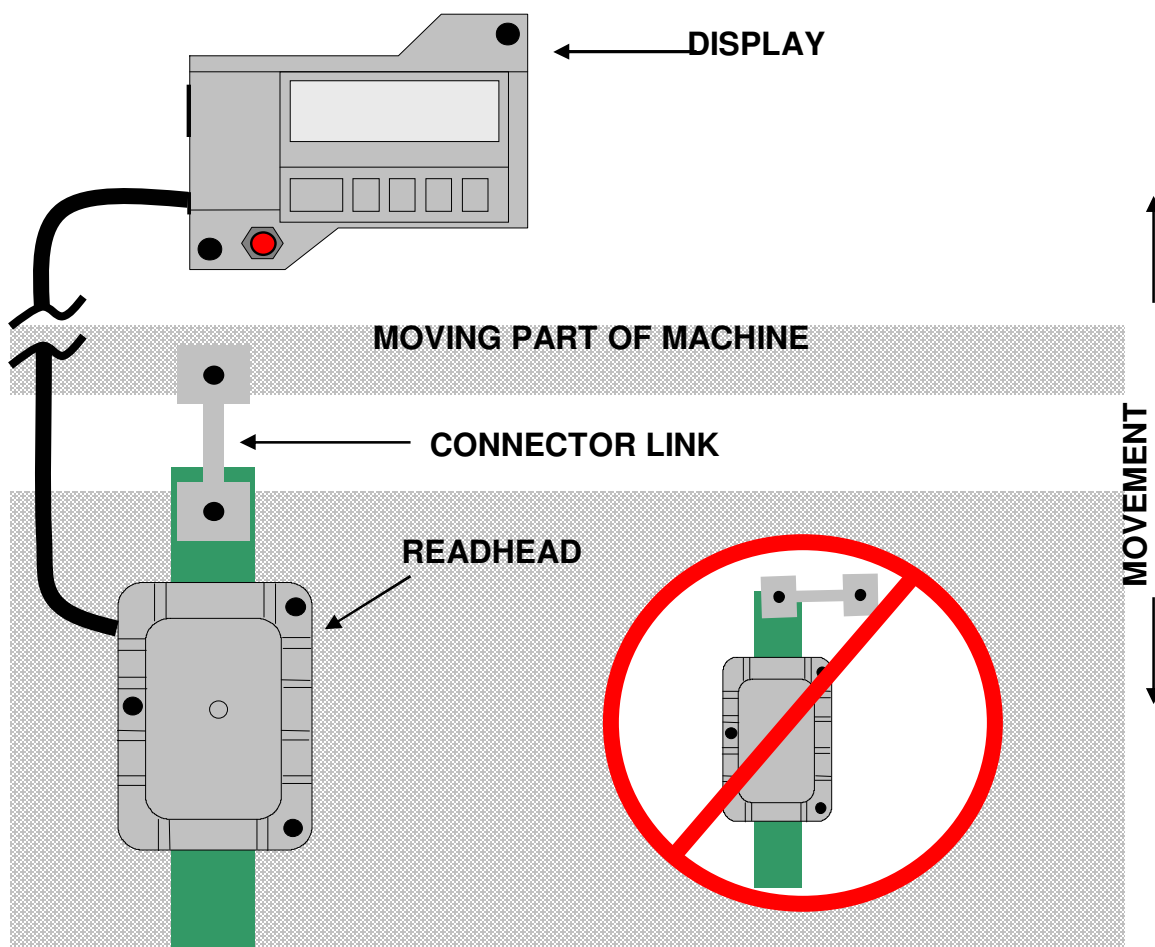

A Typical Model 150 Installation

Calibration:

The following example uses the General Purpose Display:

Once installed, ProScale can be calibrated easily and quickly. Following is an example for calibrating ProScale on an industrial sander. Other installations follow the same general procedure.

1. Check to be sure installation of all parts is complete, all fasteners are secure, and the display is plugged in.
2. Set the machine to operate as normal. Run a part through the sander.
3. Measure the thickness of the sanded part with the most precise measuring tool available (digital calipers if possible).
4. Press the zero key on the ProScale digital display.

Note: If the direction of movement and the direction shown on the digital display are opposite, the programming or position of internal jumpers should be changed. See Section 4 Digital Displays for more information.

5. Press and hold the PLUS key to scroll until the thickness measurement is displayed (the longer the PLUS key is held down, the faster the display will scroll).
6. When the proper reading is reached, lock the display if desired. This prevents accidentally re-zeroing of the display. See Section 4 for more information about how to lock the display.
7. Re-calibrate, if necessary, after changing sanding belts (or applicable tooling).
8. Calibration is not necessary after batteries are changed.

Maintenance:

The aluminum scale should be cleaned of debris often. This will prevent premature damage to the scale or readhead. Should the scale become difficult to move, check that it is thoroughly cleaned. Find and remove any burrs, which may have developed on the aluminum scale. Do not use any liquid lubricants on the scale assembly, as this may:

1. Impede the readhead's ability to operate properly.
2. Attract other contaminants to the scale.

The Digital Display should be cleaned periodically with compressed air to remove any dust on the lens and keys. All mounting fasteners should be checked occasionally for tightness.



ProScale Model 250

General Purpose system with eight standard measuring ranges from 450mm to 6m.

Model 250 systems use *ABS* style scales, *ABS* style readheads, and general-purpose, panel mount, or Position Control digital displays. Neither the scale nor readhead are compatible with other Accurate Technology ProScale incremental systems

ProScale is easy to install. By following the basics of good installation in this section, reliable, error-free operation is assured. Because ProScale can be installed on many different types and brands of equipment, all installations will be a little different. Therefore, it's the responsibility of the installer to choose the bolts, screws, or other mounting hardware that guarantee proper installation for optimum operation.

Note: If a custom kit was ordered which contains instructions for installing ProScale on a specific product, follow those instructions rather than the general instructions here.



Guide Clip

Installation:

1. Note the orientation of the readhead on the scale. Be sure the arrow on the readhead points towards the “**BLACK END OF SCALE**”. This orientation is critical for proper operation of ProScale. Check to be sure the mounting location for the system will allow this orientation.
2. Determine an appropriate mounting location for the system. The scale should be mounted to a **stationary** part of the machine. The readhead slides along the scale,

using the supplied guide clip to transfer machine movement to readhead movement. The Display should be mounted in a location which allows for easy viewing by the machine operator. The location of the parts should also safeguard the cable from possible damage. All ProScale wiring should be kept as far away as possible from the machine's wiring and motors. Avoid running the readhead wiring parallel to high voltage/current wiring or dust collection systems.

3. Mount the scale using M4 (or #6) screws. It may be necessary to use washers or spacers to ensure a good mount if the scale is to be mounted on an uneven surface. Be sure the screw heads do not protrude above the surface of the extrusion. If they do, they will interfere with the readhead.
 - a. Check that the scale is properly aligned with the direction of motion of the moving part (any error in alignment will be magnified by the digital components, and could cause premature failure). Adjust the scale alignment if necessary.
4. Referring to the figure, note these two installation requirements:
 - a. For accurate measurements, the guide clip should be mounted perpendicular to the direction of travel of the readhead.
 - b. Over the full range of travel, the guide clip should exert some pressure on the readhead so the two move as a single unit.

Note: Failure to use the guide clip will void the warranty.

5. Reinstall the readhead if it has been removed from the scale. Care should be taken to not damage the readhead's sensitive internal ground fingers. Also note the orientation

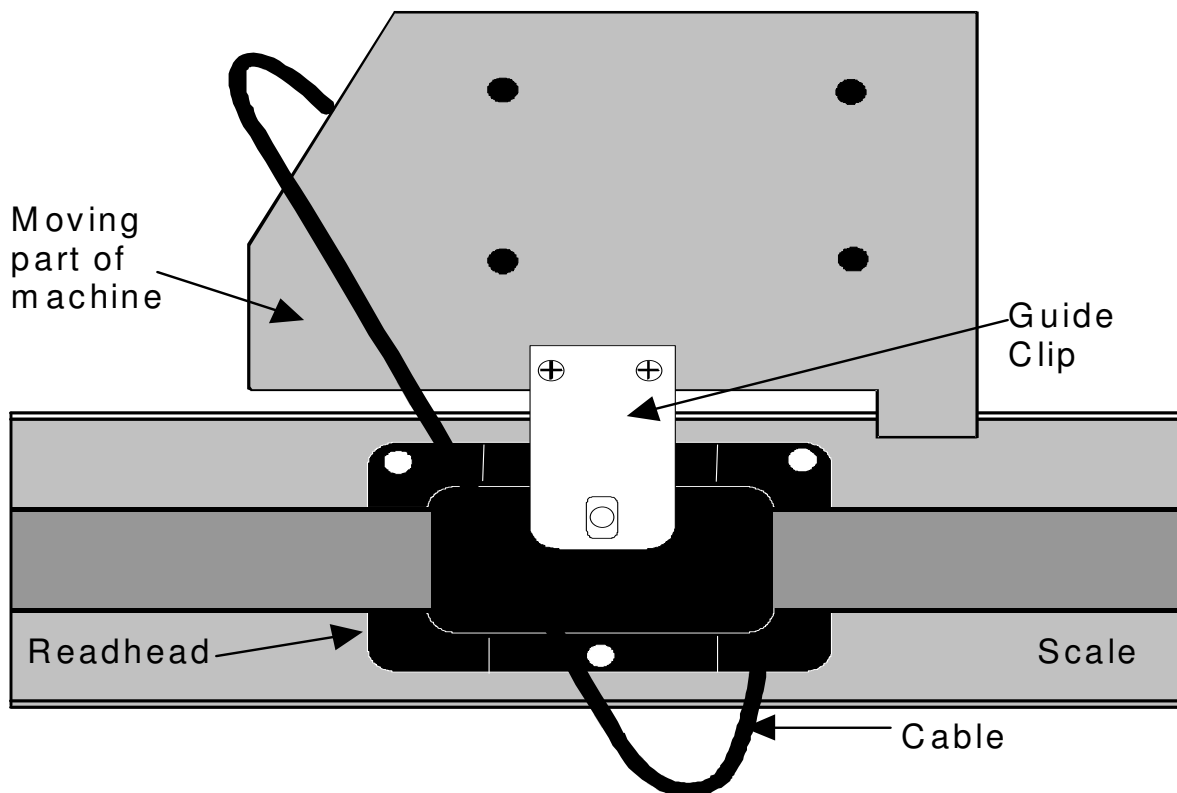

Typical Model 250 Installation

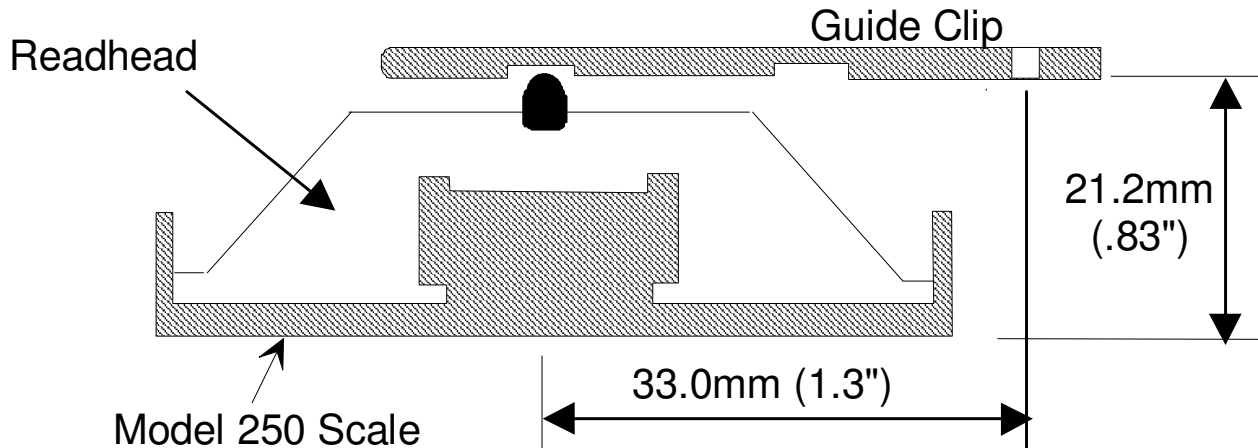

Guide Clip Pressure/Spacing

label on the readhead housing. Carefully slide the readhead onto the scale, checking for the proper orientation.

6. Slide the readhead until it meets and engages with the guide clip. Check that the guide clip exerts sufficient pressure on the readhead, as seen in the figure above.
7. Place the cable in a secure position. If necessary, fasten it with a wire tie or other fastening device. Do not leave the cable where it could be damaged or pulled from the readhead. If the application requires over twenty feet of cable, the display may need to be modified for proper operation. Also, if the application requires a shorter scale, please call Accurate Technology for assistance.
8. Plug the readhead into the display. See Section 4 regarding mounting and use of different display versions.

Note: If any other mounting method is used, observe the following:

- a. *Do not drill through the green portion of the scale at any point over which the readhead will travel.*
- b. *Do not mount the scale so the mounting hardware interferes with the movement of the readhead.*

Calibration:

The following example uses the General Purpose Display:

Once installed, ProScale can be calibrated easily and quickly. Following is an example for calibrating ProScale on a table saw fence. Other installations follow the same general procedure.

1. Check to be sure installation of all parts is complete, all fasteners are secure, and the display is plugged in.
2. Cut a part using the normal fence operation.

-
3. Measure the length of the part with the most precise measuring tool available (i.e. digital calipers).
 4. Press the zero key on the ProScale digital display.
Note: If the direction of movement and the direction shown on the digital display are opposite, the programming or position of internal jumpers should be changed. See Section 4 Digital Displays for more information.
 5. Press and hold the PLUS key to scroll until the length measurement is displayed (the longer the PLUS key is held down, the faster the display will scroll).
 6. When the proper reading is reached, lock the display if desired. This prevents accidentally re-zeroing of the display. See Section 4 for more information about how to lock the display.
 7. Re-calibrate, if necessary, after changing saw blades (or applicable tooling).
 8. Calibration is not necessary after batteries are changed.

Maintenance:

The aluminum scale should be cleaned of debris often. This will prevent premature damage to the scale or readhead. Should the readhead assembly become difficult to move, check that the scale is thoroughly cleaned. Find and remove any burrs, which may have developed on the aluminum scale. Do not use any liquid lubricants on the scale assembly, as this may:

1. Impede the readhead's ability to operate properly.
2. Attract other contaminants to the scale.

The Digital Display should be cleaned periodically with compressed air to remove any dust on the lens and keys. All mounting fasteners should occasionally be checked for tightness. If there is any wear on the green laminate of the scale, the guide clip pressure on the readhead should be reduced. If wear continues, the readhead bearing should be replaced. Call Accurate Technology for assistance

SECTION 4

DIGITAL DISPLAYS

Accurate Technology makes several digital displays for use with ProScale Model 150 and Model 250. The following is a listing of the displays and their descriptions:

General Purpose Display

Basic (no keypad) and Full Functionality
2AA Battery operated LCD
P/N 701-1600-001 (with Keypad)
P/N 701-1600-020 (without Keypad)



1/4 DIN Panel Mount

2D Battery LCD
P/N 701-1570-001
24VDC LCD
P/N 701-1560-001



1/8 DIN Panel Mount

24VDC LED
RS485 Output
CE Certified
P/N 701-1530-000



1/4 DIN Panel Mount*

24VDC Backlit LCD
Position Control Unit
P/N 701-1540-001
SEPARATE MANUAL



Dual Input Panel Mount*

24VDC 2 line Backlit LCD
2 inputs, A+B, A-B, RS232 out
P/N 701-1620-001
SEPARATE MANUAL



It is very important to use the correct instructions for each display.

***Not covered in this manual. See individual manual for this display.**

General Purpose Display



General Purpose Digital Display with Keypad
Part # 701-1600-001



General Purpose **BASIC** Digital Display
Part # 701-1600-002

Display Power

Momentarily pressing the **ON/OFF** key will cause the unit to turn the display on or off. While on, if no key presses or positional changes occur for more than 15 minutes, the ProScale will automatically turn itself off to conserve battery life. While off, if a position change is detected or the **ON/OFF** button is pressed, the display will automatically turn itself on.

Programming the Display

Several functions of the digital display are user programmable. The following instructions describe how to change the system's factory defaults.

To enter programming mode, press and hold the MODE key and momentarily press the 0 key. Release the MODE key.

The display shows the current parameter ID in the format: **Pr x** (where x is the parameter number). After approximately 1 second, the display will change to show the current value of the parameter. Use the + or – keys to change the value.

Press and hold the MODE key to show the current parameter number again.

Momentarily press the MODE key to move to the next parameter. When the desired parameter is reached (and the MODE key is no longer depressed), the value of the parameter will be displayed. When the end of the parameter list is reached, the display will loop back to parameter 0.

To exit programming mode, press and hold the MODE key then momentarily press the 0 key. Release the MODE key.

Parameters are listed below. (Values in { } are the available range of values that can be programmed for an entry. Factory defaults are shown in **bold**.)

Pr0 – Reading Direction {0,1}

Change the value to reverse the direction for positive readings.

Pr1 – Enable/Disable Long Absolute Scales {0, 1}

0=For scale lengths shorter than 430mm, and ALL incremental scales

1=For scale lengths longer than 430mm, absolute style ONLY

Pr2 – Enable/Disable Offset Entry {0,1}

0=Disables operation of Zero, + and – keys (display will be in Lock Mode)

1=Enables operation of Zero, + and – keys

Pr3 – Auxiliary Keypad Keys {0..7}

ABS/INC Button = 1

Monitor Button = 2

Hold Button = 4

To enable buttons, add up combination of button values. A value of 0 disables all three buttons. A value of 7 enables all 3 buttons.

Pr4 – Future Enhancement DO NOT CHANGE {0..63}

Pr5 – Future Enhancement DO NOT CHANGE {0..31}

Pr6 – Future Enhancement DO NOT CHANGE {0, 1}

Pr7 – Display Resolution {0, 1, or 2}

Sets the displayed resolution in decimal mode.

0 = Reduced resolution. Inch = xxx.xx MM = xx.x

1 = Normal resolution. Inch = xxx.xxx MM = xx.xx

2 = Increased resolution (changes inch readings only). Inch = xx.xxxx MM = xx.xx (This limits the display to readings under 100 inches.)

Pr8 – Metric Display Mode {0, 1}

Controls whether the position is displayed in millimeters or centimeters when in metric mode.

0 = millimeters

1 = centimeters

Pr9 – Scaling Factor {.001 .. 99.999}

The multiplier applied to the readhead input. Scaling factors less than 1.000 will make the displayed distance less than the actual distance. Scaling factors greater than 1.000 will make the displayed distance greater than the actual distance.

Pressing the 0 key restores the **default value of 1.000** (No Scaling).

PrA – Drift Tolerance {.03 .. } mm, {.001 ..} inch

Defines the tolerance of motion allowed (+/-) while the ProScale is in Monitor mode.

Default = .01in.

PrB – Disable Fractions/Inches {0, 1, 2}

0 = Allows the display to show all measurement modes (decimal inch, fractional inch, millimeters and centimeters)

1 = Disables the display of fractional inches. Only decimal inches and metric units can be displayed.

2 = Displays only metric units. No decimal or fractional inch display.

Position Display Units

The digital display can show position information in decimal inches, fractional inches or millimeters/centimeters. To change the current display mode, momentarily press the Mode key. With each key press, the unit will cycle from decimal inches to fractional inches (1/16), (1/32), (1/64) and then to metric. Pressing the Mode key again returns the unit to decimal inches. When the display is in a “fraction” mode, each bar in the display's upper right corner represents an additional 1/64th of an inch.

Measuring Modes *(on displays equipped with Auxiliary Keypad)*

The digital display has two measurement modes. One is referred to as Absolute (ABS) and the other is Incremental (INC). The Absolute measurement system is designed to allow the user to set a current position on the display referenced from a fixed position such as a saw blade, fence or stop. The Incremental measurement system is designed to take distance measurements from one arbitrary point to another. The systems operate independently allowing separate positions offsets to be programmed.

Absolute (ABS) Mode – The ProScale automatically enters ABS mode when power is first applied. This is indicated by the ABS symbol in the upper left corner of the display. While in the ABS mode, all position measurements are related to the current system reference (i.e. saw, fence, etc.) To enter the INC mode, momentarily press the ABS/INC button.

Incremental (INC) Mode – While in the INC mode, the INC symbol is shown in the upper left corner of the display. When the INC mode is initially entered, the displayed position will change to reflect a new reference point from the current position of the readhead. This is typically a position of 0 but may be changed by using the + or - keys to provide a distance offset. This offset may be used to compensate for the kerf of a saw or other requirements. Moving the readhead in either direction will display the distance moved from the initial starting point (plus offset). To complete another incremental measurement from the new current position, momentarily press the ABS/INC key. The display will again change to either 0 or the previously programmed offset. To return to the ABS mode, press and hold the ABS/INC key for approximately 3 seconds.

Offset Adjustment

Use the +, - and 0 keys to change the currently displayed position to a different value. The zero key forces the unit to display 0. Momentarily depressing the + key increments the current position by one unit (.001" or .01mm). Momentarily depressing the – key decrements the current position by one unit. Pressing and holding the + or – keys will cause the displayed position to change continuously. Continued holding of the key will cause the amount of change to increase from 1 unit to 10 units, then 100 units, etc. This allows for quick adjustments over a range of large values.

Lock Mode

The user can “lock-out” the position offset adjustment functions (+, -, 0 keys) to prevent accidental changes of the current displayed position. To activate the lock mode, press and hold the On/Off key and then momentarily press the Mode key. The LOCK symbol on the LCD display will turn on and off with each key operation. When the LOCK symbol is displayed, the +, - and 0 keys will not change the displayed position. ABS and INC modes have independent lock operations. (The ABS mode can be locked while the INC mode is unlocked).

Hold Mode *(on displays equipped with Auxiliary Keypad)*

The ProScale unit provides a feature that allows the displayed position to be “frozen” in time while the readhead is moved from its initial position. This allows measurements to be captured on the display and held for later viewing regardless of the current readhead position. To activate the Hold mode, momentarily press the Hold key. The HOLD symbol will be shown in the upper left corner of the display. The currently displayed position will be frozen from this point. To release the hold feature, momentarily press the Hold key again.

Position Monitor Mode *(on displays equipped with Auxiliary Keypad)*

The ProScale display has the ability to monitor a preset position to detect position drift caused by machine vibration or other factors. To activate the monitoring mode, position the readhead to the desired location and momentarily press the MON key. The ABS symbol will flash on the display to indicate that the position monitor mode is active.

If the readhead moves outside the programmed tolerance (see programming parameter A), the displayed position also flashes, indicating a drift condition. When the readhead is moved back within the programmed tolerance, the displayed position will stop flashing.

To exit the position monitor mode, momentarily press the MON key. This can be done regardless of whether the display is indicating a drift condition. The ABS symbol will stop flashing and if the position was previously drifted, the currently displayed position will also stop flashing.

NOTE: Position monitor mode can only be activated while in the ABS measuring mode. If the ABS/INC key is depressed while monitoring, the position-monitoring mode is automatically exited.

Segment Offset Adjustment

ProScale encoder scales that are shorter than 17 inches are designed with an absolute measurement encoder pattern such that the readhead can calculate its position directly from this pattern. For encoder scales that are longer than 17 inches, multiple encoder pattern segments are installed end-to-end on the aluminum scale extrusion. This provides a pseudo-absolute measurement capability in which the readhead can calculate its position on any individual encoder scale segment but cannot determine which encoder segment it is on. To solve this problem, the ProScale display tracks which encoder scale segment the readhead is on by detecting the readhead crossing from one encoder segment to encoder segment.

In certain situations, the crossing from one segment to another may not be detected by the display. This may occur if the readhead is disconnected from the display and then moved along the scale to another encoder segment. It may also occur if the readhead is moved too quickly between two encoder segments.

If the encoder segment tracking count is incorrect because of one of the above situations, the user can re-adjust the display to correct the error. This modification is referred to as the Segment Offset Adjustment.

To add one encoder segment to the displayed value, press and hold the Mode key and then momentarily press the + key. The displayed position will increase by 16.932 inches. To subtract one encoder segment from the displayed value, press and hold the Mode key and then momentarily press the - key. The displayed position will decrease by 16.932 inches.

Sending Data to SPC device *(on displays equipped with Auxiliary Keypad)*

The ProScale display provides an output port that can be used to send position information to a compatible SPC device such as a printer or data acquisition device. After connecting the SPC device to the ProScale display, the user may initiate the data transmission by momentarily pressing the SEND key. This signals the SPC device to acquire the data from the ProScale display.

The data format and connector style of the ProScale SPC output is the same as Mitutoyo SPC. This is an industry standard that can be interfaced with most available SPC products including multiplexers, RS232 converters and PC plug-in boards. Data from the ProScale is sent to the SPC connector in either millimeters or decimal inches.

If no SPC device is attached to the display, the SEND key has no other function.

See *Section 6 Accessories* for interface/data acquisition products descriptions

F1 /F2 *(on displays equipped with Auxiliary Keypad)*

For Future and/or Custom programming functions. These keys are currently not active.

Jumpers

Although the ProScale display uses a keyboard-programming mode to set features in the unit, several selection jumpers are located on the circuit board for special functions.

JP1 Absolute/Incremental Encoder Selection

The ProScale General Purpose Display supports both the Accurate Technology incremental and absolute style systems. To configure the display for use with absolute type encoders (default), install the shorting jumper in position A. For incremental type encoders, install the shorting jumper in position B.

(ProScale Model 150 & 250 are Absolute systems. Other Accurate Technology products such as ProCaliper, ProPanel, Measurement Kits, and ProStop are Incremental systems)

NOTE: This functionality is not related to the Absolute and Incremental measurement modes described earlier.

JP2 FUTURE FEATURE DO NOT CHANGE !

JP4 Programming Mode Control

Entry to the programming mode of the ProScale display can be enabled or disabled based on this jumper setting. To enable keyboard programming (default), install the shorting jumper in position A. To disable keyboard programming, install the shorting jumper in position B.

When programming mode is disabled, the user cannot access the programming functions via the **Mode/0** keys as described in the programming section. This provides the user with a method of configuring the display with specific parameters and prevents unauthorized configuration changes.

All Jumpers are shown in "storage" position for best visibility

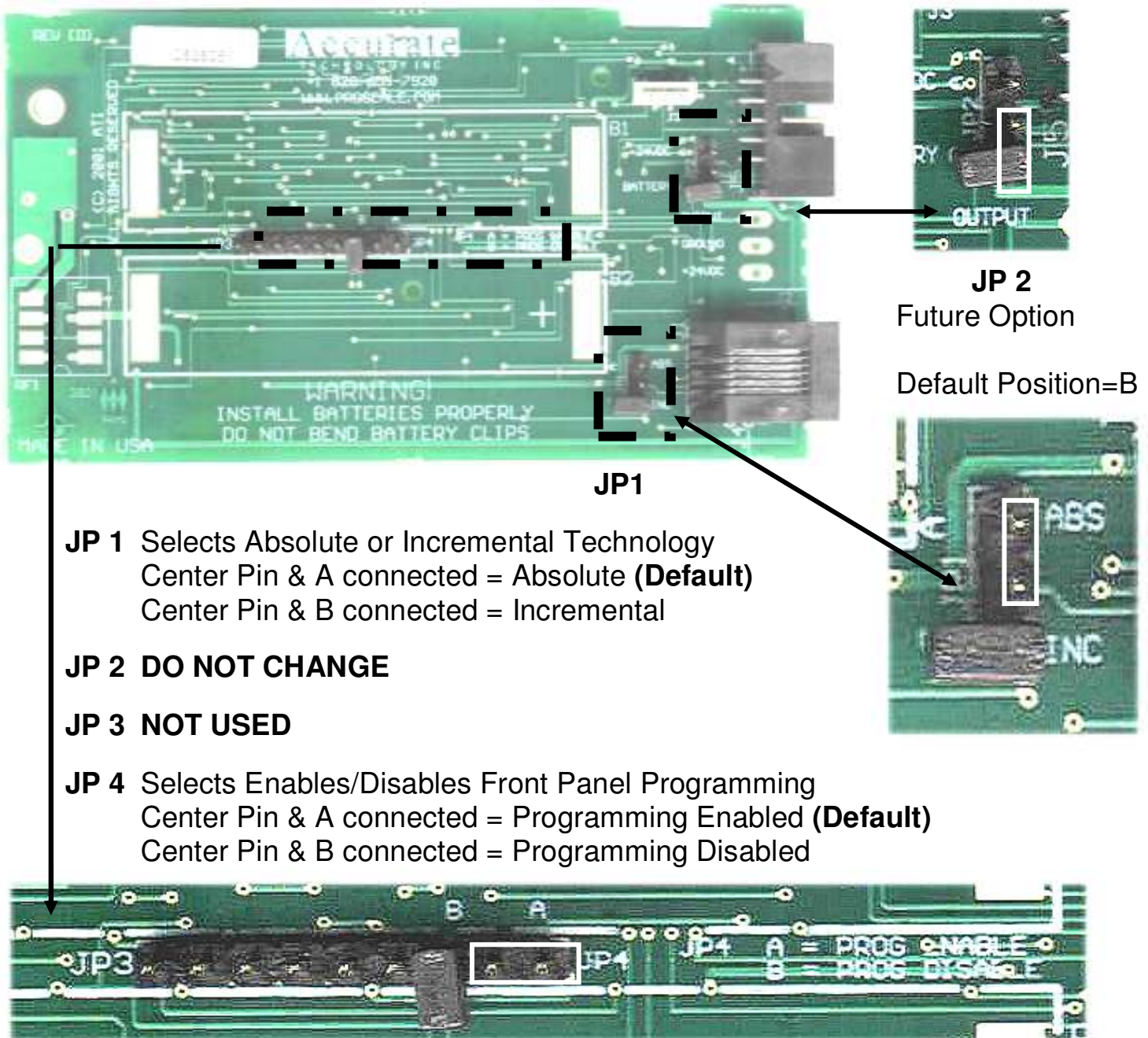

JP 1 Selects Absolute or Incremental Technology
Center Pin & A connected = Absolute (**Default**)
Center Pin & B connected = Incremental

JP 2 DO NOT CHANGE

JP 3 NOT USED

JP 4 Selects Enables/Disables Front Panel Programming
Center Pin & A connected = Programming Enabled (**Default**)
Center Pin & B connected = Programming Disabled

Changing the Batteries

To change the batteries, remove the two screws holding the cover to the base of the display housing. Carefully pull off the cover. Remove the batteries. Reinstall new ones, noting the proper orientation shown in the battery compartment. Replace the cover and tighten the screws. Note: **DO NOT BEND BATTERY CLIPS!**

Mounting the Display

There are four small mounting holes in the back of the display which may be tapped for M2 or 4-40 screws. The display may also be mounted using double sided tape or Velcro.

1/4 DIN LCD Panel Mount Displays

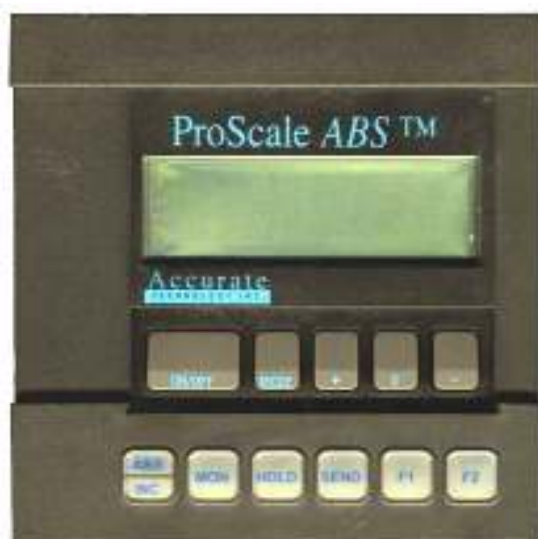

Panel Mount Digital Display – Part # 701-1560-001(24VDC), 701-1570-001 (2D Battery)

Power Supply

There are two versions of the 1/4 DIN Panel mount displays.

Part # 701-1570-001, is powered by two "D" cell batteries.

Part # 701-1560-001, is powered by 24 volts DC.

Mounting the Display

A cutout must be made in the panel where the display is to be mounted. The cutout should measure at least 90mm x 90mm (3.6 x 3.6 inches). The cutout should measure no larger than 93mm x 93mm (3.7 x 3.7 inches).

The casing of the panel mount displays "sandwich" a panel between the front cover and the rear cover. The displays are designed to accommodate any panel thickness between 0.125" and 0.750".

Note: For any panel thinner than 0.125 inches, shorter screws must be used for the display casing. If shorter screws are not used, damage to the front cover will occur.

Changing the Measurement Mode:

Press the MODE key to change the measurement readout. The current measurement readout is saved when power is off. Readouts appear in the following order:

Millimeters xxxx.xx

Decimal inches xxx.xxx

Fractions 16ths, 32nds, 64ths

Each bar in the display's upper right corner represents an additional 1/64th of an inch.

Programming the Display

To customize the Digital Display, several functions are user programmable. The following instructions describe how to change the system's factory defaults.

To enter programming mode, press and hold the MODE key and momentarily press the 0 key. Release the MODE key.

The display shows the current parameter ID in the format: Pr x where x represents the parameter number. After approximately 1 second, the display will change to show the current value of the parameter. Use the + or – keys to change the value. Binary (0 or 1) values can be toggled to opposite values by pressing either the + or – keys. Other values are incremented with the + key or decremented with the – key.

Pressing and **holding** the MODE key will show the currently selected parameter number without moving to the next parameter. Releasing the MODE key will again display the parameter value.

Momentarily pressing the MODE key will move to the next parameter, displaying the parameter ID for 1 second and then the parameter value. Successive momentary presses of the MODE key will quickly migrate down the parameter list without displaying each parameter value. When the desired parameter is reached and the MODE key is no longer depressed, the parameter value will then be displayed. When the end of the parameter list is reached, the display will loop back to parameter 0.

To exit programming mode, press and hold the MODE key then momentarily press the 0 key. Release the MODE key.

The following parameters are available for programming. Values within { } reflect the available range of values that can be programmed for an entry.

Factory defaults are shown in **bold**

Pr0 – Encoder Direction {0,1}

Changes the Display readings from Positive to Negative or visa-versa.

Pr1 – Enable/Disable Long Scales {0, 1}

0=For scale lengths less than 430mm (17in.)

1=For scale lengths greater than 430mm (17in.)

Pr2 – Enable/Disable Offset Change {0,1}

0=Disallows Zero, + and – keys operation (display will be in Lock Mode)

1=Allows Zero, + and – keys to zero reading, increment/decrement readings

Pr3 – Aux Keypad Key Enable {0..7}

ABS/INC Button = 1

Monitor Button = 2

Hold Button = 4

To enable buttons, add up combination of button values. Store sum in Pr3. A value of 0 disables all three buttons. A value of 7 enables all 3 buttons.

Pr4 – Future Enhancement DO NOT CHANGE {0..63}

Pr5 – Future Enhancement DO NOT CHANGE {0..31}

Pr6 – Future Enhancement DO NOT CHANGE {0, 1}

Pr7 – Display Resolution {0, 1, or 2}

Sets the displayed resolution in decimal mode.

0 = Reduced resolution. Inch = xxx.xx MM = xx.x

1 = Normal resolution. Inch = xxx.xxx MM = xx.xx

2 = Increased resolution (Inch only). Inch = xx.xxxx MM = xx.xx

Pr8 – Metric Display Mode {0, 1}

Controls whether the position is displayed in millimeters or centimeters when the metric display mode is selected.

0 = millimeters

1 = centimeters

Pr9 – Scaling Factor {.001 .. 99.999}

Applies a scaling factor to the encoder position with the result being displayed as the current position. Scaling factor values less than 1.000 result in displayed positions less than the actual position. Values greater than 1.000 result in displayed position greater than the actual position. Pressing the 0 key restores the **default value of 1.000** (No Scaling).

PrA – Drift Tolerance {.03 .. } mm, {.001 ..} inch

Defines a tolerance of motion allowed (+/-) while the ProScale is in Monitor mode.

This tolerance value is automatically converted to the appropriate units based on the currently selected display units. **Default =. 01in.**

PrB – Disable Fractions/Inches {0, 1, 2}

0 = Allows the display to show all measurement modes (decimal inch, fractional inch, millimeters and centimeters)

1 = Inhibits the display of fractional inches. Only decimal inches and metric units can be displayed.

2 = Displays Only metric units. No inch display of any kind.

Position Display Units

The ProScale measurement system can display position information in decimal inches, fractional inches or millimeters/centimeters. To change the current display mode, momentarily press the Mode key. With each key activation, the unit will cycle from decimal inches to fractional inches (1/16), (1/32), (1/64) and then to millimeters/centimeters. Pressing the Mode key again returns the unit to decimal inches. When the display is in a “fraction” mode, each bar in the display's upper right corner represents an additional 1/64th of an inch.

Measuring Modes *(on displays equipped with Auxiliary Keypad)*

The ProScale display has two measurement modes. One is referred to as Absolute (ABS) and the other is Incremental (INC). The Absolute measurement system is designed to allow the user to set a current position on the display referenced from a fixed position such as a saw blade, fence or stop. The Incremental measurement system is designed to take distance measurements from one arbitrary point to another. Both systems operate independently allowing separate positions offsets to be programmed.

Absolute (ABS) Mode – The ProScale automatically enters ABS mode when power is first applied. This is indicated by the ABS symbol in the upper left corner of the display. While in the ABS mode, all position measurements are related to the current system reference (i.e. saw, fence, etc.) To enter the INC mode, momentarily press the ABS/INC button.

Incremental (INC) Mode – While in the INC mode, the INC symbol is shown in the upper left corner of the display. When the INC mode is initially entered, the displayed position will change to reflect a new reference point from the current position of the readhead. This is typically a position of 0 but may be changed by using the + or - keys to provide a distance offset. This offset may be used to compensate for the kerf of a saw or other requirements. Moving the readhead in either direction will display the distance moved from the initial starting point. To complete another incremental measurement from the new current position, momentarily press the ABS/INC key. The display will again change to either 0 or the previously programmed offset. To return to the ABS mode, press and hold the ABS/INC key for approximately 3 seconds.

Offset Adjustment

Use the +, - and 0 keys to change the currently displayed position to a different value. The zero key forces the unit to display 0. Momentarily depressing the + key increments the current position by one unit (.001” or .01mm). Momentarily depressing the – key decrements the current position by one unit. Pressing and holding the + or – keys will cause the displayed position to change continuously. Continued holding of the key will cause the amount of change to increase from 1 unit to 10 units, then 100 units, etc. This allows for quick adjustments over a range of large values.

Lock Mode

The user can “lock-out” the position offset adjustment functions (+, -, 0 keys) to prevent accidental changes of the current displayed position. To activate the lock mode, press and hold the On/Off key and then momentarily press the Mode key. The LOCK symbol on the LCD display will turn on and off with each key operation. When the LOCK symbol is displayed, the +, - and 0 keys will not change the displayed position. ABS and INC modes have independent lock operations. That is to say that the ABS mode can be locked and the INC mode can be unlocked.

Display Hold Mode *(on displays equipped with Auxiliary Keypad)*

The ProScale unit provides a feature that allows the displayed position to be “frozen” in time while the readhead is moved from its initial position. This allows measurements to be captured on the display and held for later viewing regardless of the current readhead position. To activate the Hold mode, momentarily press the Hold key. The HOLD symbol will be shown in the upper left corner of the display. The currently displayed position will be frozen from this point. To release the hold feature, momentarily press the Hold key again.

Position Monitor Mode *(on displays equipped with Auxiliary Keypad)*

The ProScale display has the ability to monitor a preset position to detect position drift caused by machine vibration or other factors. To activate the monitoring mode, position the readhead to the desired location and momentarily press the MON key. The ABS symbol will flash on the display to indicate that the position monitor mode is active.

If the readhead is moved outside the programmed tolerance (programming parameter A), the displayed position will also flash indicating a drift condition. When the readhead is moved back within the programmed tolerance, the displayed position will stop flashing.

To exit the position monitor mode, momentarily press the MON key. This can be done regardless of whether the display is indicating a drift condition. The ABS symbol will stop flashing and if the position was previously drifted, the currently displayed position will also stop flashing.

NOTE: Position monitor mode can only be activated while in the ABS measuring mode. If the ABS/INC key is depressed while monitoring, the position-monitoring mode is automatically exited.

Segment Offset Adjustment

ProScale encoder scales that are shorter than 17 inches are designed with an absolute measurement encoder pattern such that the readhead can calculate its position directly from this pattern. For encoder scales that are longer than 17 inches, multiple encoder pattern segments are installed end-to-end on the aluminum scale extrusion. This provides a pseudo-absolute measurement capability in which the readhead can calculate its position on any individual encoder scale segment but cannot determine which encoder segment it is on. To solve this problem, the ProScale display tracks which encoder scale

segment the readhead is on by detecting the readhead crossing from one encoder segment to encoder segment.

In certain situations, the crossing from one segment to another may not be detected by the display. This may occur if the readhead is disconnected from the display and then moved along the scale to another encoder segment. It may also occur if the readhead is moved too quickly between two encoder segments.

If the encoder segment tracking count is incorrect because of one of the above situations, the user can re-adjust the display to correct the error. This modification is referred to as the Segment Offset Adjustment.

To add the distance of one encoder segment, to the display, press and hold the Mode key and then momentarily press the + key. The displayed position will increase by 16.932 inches.

To subtract the distance of one encoder segment, to the display, press and hold the Mode key and then momentarily press the - key. The displayed position will decrease by 16.932 inches.

Sending Data to SPC device *(on displays equipped with Auxiliary Keypad)*

The ProScale display provides an output port that can be used to send position information to a compatible SPC device such as a printer or data acquisition device. After connecting the SPC device to the ProScale display, the user may initiate the data transmission by momentarily pressing the SEND key. This signals the SPC device to acquire the data from the ProScale display.

The data format and connector style of the ProScale SPC output is the same as Mitutoyo SPC. This is an industry standard that can be interfaced with most available SPC products including multiplexers, RS232 converters and PC plug-in boards. Data from the ProScale is sent to the SPC connector in either millimeters or decimal inches.

If no SPC device is attached to the display, the SEND key has no other function.

See *Section 6 Accessories* for interface/data acquisition products descriptions

F1 /F2 *(on displays equipped with Auxiliary Keypad)*

For Future and/or Custom programming functions. These keys are currently not active.

Jumpers

Although the ProScale display uses a keyboard-programming mode to set features in the unit, several selection jumpers are located on the circuit board for special functions.

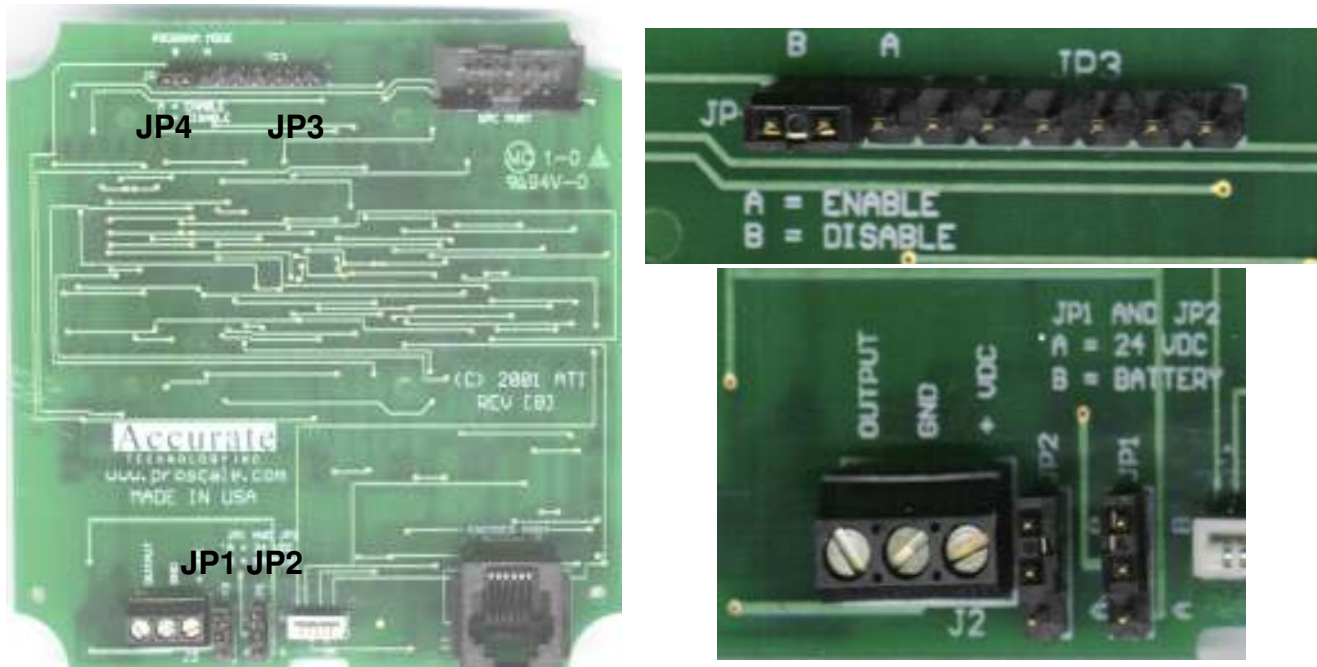

JP1 and JP2 Power Selection

The Panel Mount Display supports either 2 D size battery OR 24VDC operation. JP1 and JP2 are used to configure the display for the appropriate power.

For 24VDC operation set jumpers JP1 AND JP2 in the “A” position (shunt placed across center pin and “A” pin).

For battery operation set jumpers JP1 AND JP2 in the “B” position (shunt placed across center pin and “B” pin).

JP3 Not used at this time

JP4 Programming Mode Control

Entry to the programming mode of the ProScale display can be enabled or disabled based on this jumper setting. To enable keyboard programming (default), install the shorting jumper in position A. To disable keyboard programming, install the shorting jumper in position B.

When programming mode is disabled, the user cannot access the programming functions via the **Mode/0** keys as described in the programming section. This provides the user with a method of configuring the display with specific parameters and prevents unauthorized configuration changes.

1/8 DIN LED Panel Mount Displays

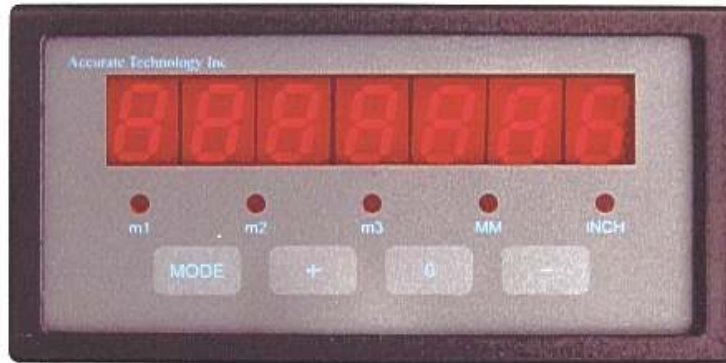

LED Display System Features

- System can be programmed to display in millimeters or decimal inches.
- Two independent absolute measurement modes (m1 and m2) with programmable incremental mode (m3). Incremental mode can be programmed as:
 - Incremental mode disabled.
 - Incremental mode with resettable kerf adjustment.
 - Third independent absolute mode.
- Programmable offsets for both m1 and m2 absolute modes and m3 incremental mode.
- Offset lockout in both incremental and absolute modes.
- Offset programming disable via system programming.
- System configuration using keyboard programming.
- Programming lockout capability using jumper selection.
- Program functions stored in non-volatile memory (EEPROM).
- Multi-segment ABS scale capability.
- RS-485 communication bus allows up to 32 individual displays to be connected on single twisted pair cable.
- Programmable scaling factor (.001 to 9.999).
- Programmable scale direction for sign correction.
- Auto exit from program mode (1-minute idle time).
- Optional programmable upper and lower limits with optically isolated output.
- Operates from 14 to 24 volts DC.
- Multi-stage transient voltage protection.

Keypad Functions

MODE – Activates the following functions depending on operating state:

- Selects absolute m1 or m2 modes or incremental m3 mode of operation during normal use.
- Press and hold for offset lock.
- Advances to next programming option while in programming mode.
- Acts as a “SHIFT” key to execute special operations:
- Mode and 0 = Programming Mode entry and exit.
- Mode and + = Add segment in multi-segment mode.
- Mode and - = Subtract segment in multi-segment mode.

+ (PLUS)

- Adds to position offset value in normal use.
- Increments value of programming option while in program mode.

ZERO

- Sets current displayed position to zero in either ABS or INC modes if offset programming is NOT locked.

- (MINUS)

- Subtracts from position-offset value in normal use.
- Decrements value of programming option while in program mode.

ABS and INC Operating Modes

The independent absolute measurement modes m1 and m2 are used to display a position from a fixed reference point on the machine or coordinate system. The **PLUS**, **ZERO** and **MINUS** keys can be used to apply a position offset while the offset LOCK feature is not enabled.

The INC coordinate system can be operated in one of three modes:

- Disabled
- Automatic kerf adjustment
- Third coordinate system similar to ABS m1 and m2

If disabled, INC mode cannot be activated using the **MODE** key.

In automatic kerf adjustment, an offset is programmed using the plus, zero and minus keys (assuming LOCK is not enabled). Each single depression of the **MODE** key causes the programmed offset (kerf) to be re-displayed as the current position of the scale. Pressing the **MODE** key twice within 2 seconds will return the display back to the ABS m1 mode of operation.

When programmed as a third independent absolute coordinate system, the incremental mode m3 operates exactly like ABS m1 and m2 modes. This can be useful in applications where independent coordinate systems are needed, such as vertical panel saws, etc.

Offset Locking

The ABS or INC offsets can be locked/unlocked independently of each other by depressing and holding the **MODE** key. After approximately 2 seconds, the associated coordinate system LED will flash if the offset is unlocked or remain steady on if the offset is locked. If offset change has been disabled in the programming mode (option x), both of the ABS modes and INC mode will always be in the locked state. Pressing the **MODE** key will have no effect.

Segment Adjustment

If multi-segment mode has been enabled, pressing and holding the **MODE** key along with either the **PLUS** or **MINUS** keys will adjust the segment offset by +/- one segment length for each key depression. This feature is disabled if LOCK mode is on.

Displayed Measurement Units

This function is selected via programming option 1 and can be set to millimeters or decimal inches. See the **System Programming** section for additional details.

Programmable Output

The ProScale LED display provides an optically isolated low current output that will be activated whenever the value of absolute coordinates system m1 exceeds the user defined limits. An independent upper and lower limit exists for this functionality and can be accessed via the programming mode. This output is limited to 10 mA at 24 VDC or 25 mA 12 VDC.

Electrical Connections

The illustration on the next page shows all of the electrical connections to the ProScale LED display. Power supply voltage is connected at terminals 1 and 2. RS-485 bus is connected to terminals 3 (plus) and 4 (minus). Limit output (optional) is connected to terminals 5 (positive side of circuit) and 6 (negative side of circuit).

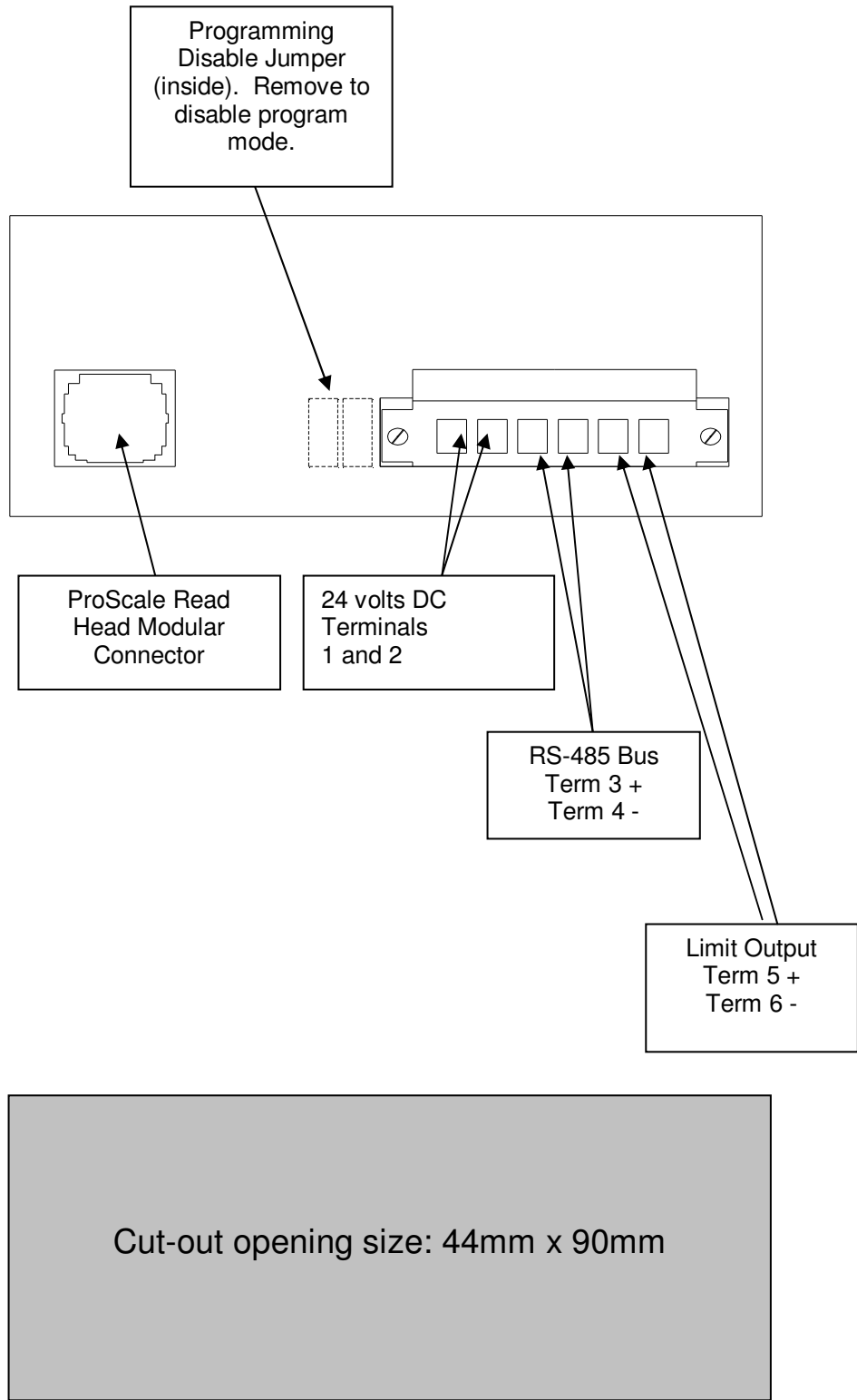

System Programming

All display operation programming is completed via the system keypad. Keypad programming can be disabled by removing the PROG jumper inside the rear panel of the display. All program parameters are maintained in non-volatile memory (EEPROM) and are preserved in the event of total power failure.

To enter the programming mode, press and hold the **MODE** key while pressing the **ZERO** key. The display will change to a value as shown below:

1	0
---	---

The left-most digit represents the programming option number (1 to b). Each of these options represents a different program parameter for the system. The number on the right represents the current value of the displayed parameter.

To change the current value of the parameter, press the **PLUS** or **MINUS** keys respectively to increase or decrease the displayed value. Each parameter has a limited range that cannot be exceeded by additional key presses of the **PLUS** or **MINUS** key.

To move to the next programming parameter, momentarily press the **MODE** key. The left digit will increment by one illustrating the current parameter value. Parameters are numbered 1 through 9, followed by a and b. When the eleventh parameter has been reached (b), pressing the **MODE** key again will restart the parameter list at 1.

To exit programming mode at any programming parameter, press and hold the **MODE** key and press the **ZERO** key. The unit will return to the normal positional display operation.

The following pages describe each programming parameter in detail.

Programming Parameters

Option 1 – Display Measurement Units. Changes the measurement units produced by the display.

- 0 = Millimeters
- 1 = Decimal Inches

Option 2 – Encoder Type Selection. Set this option to “0” only

- 0 = ProScale
- 1 = Future Feature

Option 3 – Program Offset Enable. Enables/Disables offset programming from the display keyboard. If enabled, always in LOCK mode.

- 0 = Offset Programming Disabled
- 1 = Offset Programming Enabled

Option 4 – Multi-Segment Mode. Enables multi-segment mode when using a multi-segment (Model 150-18 and all Model 250 systems) ABS ProScale.

- 0 = Multi-segment mode Disabled
- 1 = Multi-segment mode Enabled

Option 5 – Encoder Direction. Changes the sign operation on the ProScale to alter in which direction measurements are increasing or decreasing. Range is 0 or 1.

Option 6 – RS-485 Bus address for display. This programmed value uniquely identifies the display when used on a multi-point bus.

Allowable Values = 1 to 32

Option 7 – RS-485 Bus baud rate setting. The ProScale LED display supports 4 separate baud rates which are selected using values from 1 to 4. The table below illustrates the corresponding rates.

- 1 = 1200 baud
- 2 = 2400 baud
- 3 = 9600 baud
- 4 = 19200 baud

Option 8 – Scale Factor. Applies a scaling factor to the value read by the ProScale linear encoder prior to display. Range can be from .001 to 9.999. Default value is 1.000.

Option 9 – Incremental Mode Operation. Configures the operation of the incremental coordinate system (m3).

- 0 = Disable INC mode. Display operates only in ABS modes m1 and m2.

-
- 1 = Auto kerf mode. This “kerf” value is re-applied as the current position on each single press of the MODE button.
 - 2 = Incremental mode operates similar to ABS modes m1 and m2 and can be used as a third absolute coordinate system.

Option A – Programmable lower limit. References the m1 absolute coordinate system and activates the hardware output if the value of m1 decreases below this value.

Option B – Programmable upper limit. References the m1 absolute coordinate system and activates the hardware output if the value of m1 increases above this value.

Option C – Controls the state of the limit output. If C = 0 and m1 is within the limits, the output is closed. If C = 1 and m1 is within the limits, the output is open.

Option D – Streaming data output. If 0, a position request command must be issued from the host to receive position data. If 1, position data is streamed out of the bus port at the sampling rate of the encoder.

RS-485 Bus Commands

The ProScale LED display can be queried for its current position and status data via the RS-485 two-wire bus. Commands are issued using ASCII data transmitted in a packet form. The position query command (from host) is shown below:

Byte #	Meaning
1	Display Address (ASCII 1 through ASCII b)
2	Position Query Command (ASCII A)
3	Data Bytes To Follow (ASCII 0)

The ProScale LED display will respond with the following string

Byte #	Meaning
1	Echo of display address (ASCII 1 through ASCII b)
2	Number of data bytes to follow (ASCII : 10 bytes)
3	Current coordinate system (ASCII 0 = m1, 1 = m2, 2 = m3)
4	Units mode (ASCII 0 = MM, 1 = inches, 2 = degrees)
5 – 12	Position in ASCII data. Format = -xxxx.xx or -xxx.xxx

The ProScale display expects individual characters to be received no more than 100 milliseconds apart. A minimum inter-character time should be no less than 3 milliseconds. If the inter-character time exceeds 100 milliseconds, the data packet will be ignored.

The ProScale display will begin sending the requested position data within 30 milliseconds of a valid query command.

SECTION 5

MISCELLANEOUS

Scales

Scales used for individual products should never be mixed. Try to avoid drilling through the green portion of the scale. Any portion of the green that is drilled will not operate.

Note: Shortening Model 150 or Model 250 scales is not advised. Contact Accurate Technology for assistance or visit www.proscale.com/other/absscalecut.htm.

To shorten the incremental scales for an application, follow these steps. The scale is embedded with stainless-steel wires that could be damaged if not cut properly.

1. Use a grinder (such as a Moto Tool®) to grind through the wires embedded in the sides of the scale.
2. Using a hacksaw, cut through the aluminum extrusion.
3. Use a file or sanding tool to chamfer the cut end to the specifications shown in the illustration.
4. Remove all burrs.
5. Test the shortened scale by sliding a readhead on. There should not be any binding.

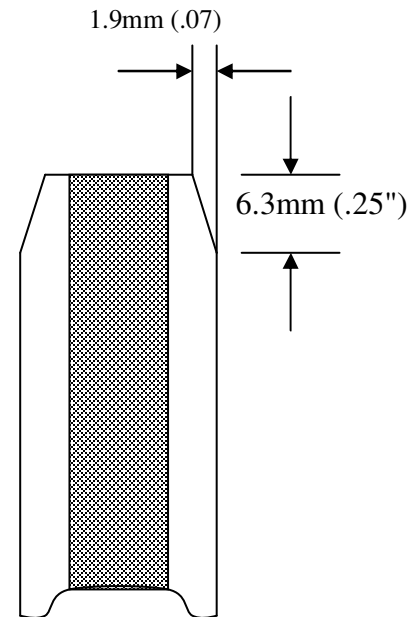

Readheads

Readheads used for individual products should never be mixed. Avoid making extension cables. If a different cable length is required, contact Accurate Technology, Inc. The pressure exerted on the readhead by the guide clip should never cause the circuit board to press against the green strip on the scale, as this will quickly wear out both components and void the warranty. See the diagram in Section 3 more information about proper guide clip spacing.

Frequently Asked Questions

Why is there an “Err 2” message on the display?

If the readhead is off the scale, or the readhead cable is unplugged from the digital display, an “Err 2” will appear on the display. To clear error:

1. Be sure the readhead is on the scale.
2. Unplug the connector from the display for one second.
3. Reconnect the readhead cable to the digital display.

Pressing ZERO, PLUS, or MINUS keys has no effect or causes the display to change approximately 17 inches:

The keypad is locked. To unlock the keypad, momentarily press and release the MODE key while holding down the ON/OFF key.

The battery clips seem to be very loose. Is this normal?

Yes. DO NOT attempt to bend these clips or wedge anything between them and the case. These clips are designed to expand when the two case halves are screwed together.

Can I mount the scale/readhead without the flex link/guide clip?

The flex link and guide clip serve to provide an accurate method of transferring the movement of the moving part to the readhead, while also absorbing any stresses that may occur. If they are not used, the warranty is voided.

The display reads numbers but they seem to be random.

Be sure the readhead is oriented correctly on the scale. One end of the scale is black. Be sure that the arrow on the readhead sticker is pointed in the correct direction.

The display does not change as the scale/readhead moves.

The display is in the HOLD mode. Press & release the Hold button.

Product Communication:

ProScale's electrical interface allows the readhead position to be read directly or through the digital display by a computer or other data acquisition device. Interface diagrams are available upon request.

Error Codes & Factory Service

ProScale warns if an error occurs by displaying "Err" plus a number on the display. If error code 0, 1, 2, 3, 5, 6, 7, or 8 is displayed:

1. Check to be sure the readhead is on the scale.
2. Check all connections and cable for damage.
3. If the readhead is on the scale and all connections are good, unplug the readhead from the display, wait 3 seconds, and reinstall it.

If error code 4 is displayed, the display is trying to display fractions over 99 $\frac{63}{64}$ ". Switch to a decimal readout or press ZERO (and recalibrate) if this value is incorrect.

For further assistance, contact your supplier, or Accurate Technology.

When calling for factory service, please have as much information about your product on-hand. If possible, please have the following information:

1. Product name.
2. Any modification to the product.
3. The date of product purchase.
4. Detailed information about the problem, such as when, where, and how the problem occurs, and the machinery being used nearby.

Abbe Error

Abbe error is a condition that may not be visible to the human eye, but will affect linear measurements. Be sure to take precautions when installing ProScale in order to eliminate the possibility for Abbe error.

Abbe error refers to a linear error caused by the combination of an angular error and a

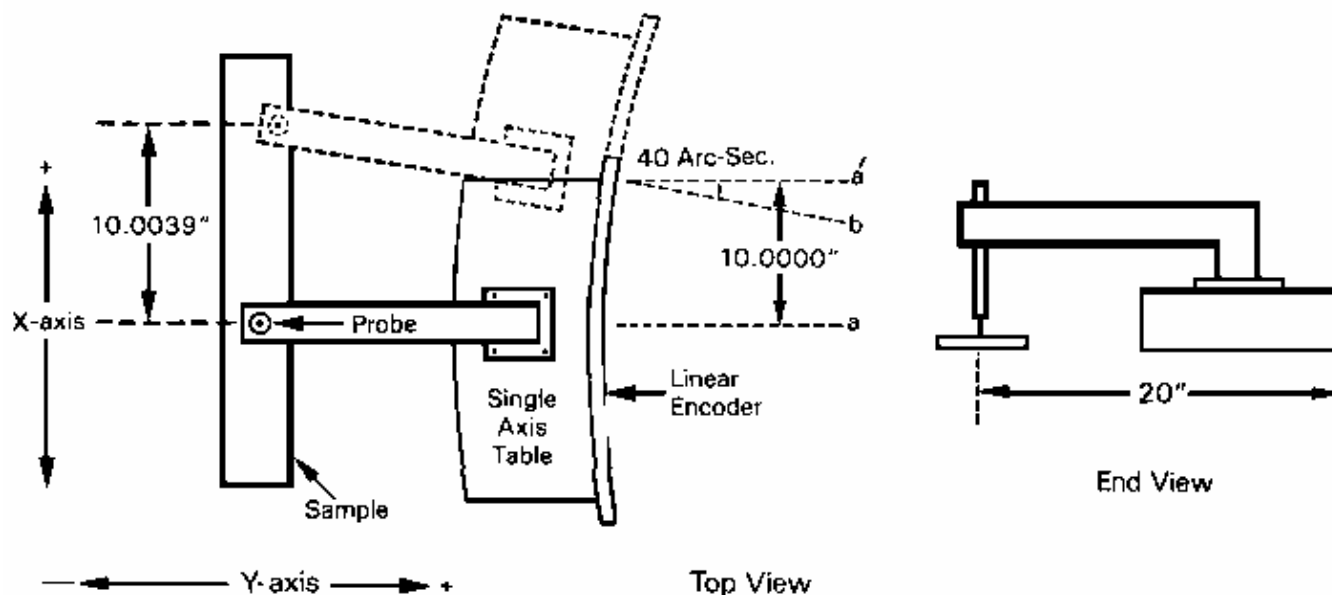

dimensional offset between the sample and the measuring system. It is important to understand that the information the encoder is providing is **only the position of the readhead on the scale**. To illustrate this, see the figure, which shows a linear measuring device. (The apparent distortion in the measuring device is intentional - for this example - to show the measuring device with a curvature in its mounting.)

Suppose the curvature in the figure is sufficient to produce an angle of 40 arc-seconds. If the measuring device moves 10 inches, the probe will be found to have moved 10.0039 inches, resulting in an error of +0.0039 inches. Abbe error could be lessened by moving the measuring system closer to the sample. This effectively solves one half of the Abbe error problem (offset) and leaves only the angular mounting problem to be solved. Angular error can best be countered through proper design and placement of the linear scale. Sources of angular error include:

1. Mounting the linear scale to an imperfectly flat surface.
2. Mounting the linear scale to an imperfectly straight surface.
3. Curvature of ways (or linear bearings) used to measure the sample.
4. Contaminants between the probe and item being measured.
5. Friction in any part(s) of the measuring device.



ProMUX-3

The ProMux 3™ is an easy to use hardware interface device providing communication and control of one to three ProScale ABS linear encoders from a user provided PC or PLC.

Supplied are two separate components. First is the ProMux 3 interface unit and second is a low voltage plug-in power supply. The user must provide the host PC or PLC and a standard DB-9 serial cable (male to female).

Uses for the ProMux 3 include axis position measurement on XY or XYZ quality control measurement tables, machinery position control (NON-CNC), tooling measurement devices and the like.

Specifications:

Encoder Inputs: 3 ProScale ABS readheads or SPC displays. ProMux 3 provides power to readheads without displays.

Serial Interface: RS-232 DB-9 connector.
8 bit word, no parity, 1 stop bit
No flow control.

Additional details in *ProMUX Family* manual



ProMUX-4, ProMUX-8

The ProMUX™ series of linear encoder multiplexers are designed for OEM and system integrators for use in acquiring setup positional information (non-CNC) on industrial production machinery.

The multiplexers interface directly with ProScale absolute linear measurement encoders. These systems provide linear measurement ranges from 100mm to 6 meters depending on the model.

ProMUX 4/8 multiplexers communicate with a host PC or PLC via RS-232 or RS-422 serial interface. Various baud rates are supported from 9600 to 115200. Up to 15 multiplexers can be connected to the same communications bus when utilizing the RS-422 serial interface.

- 14 – 24 VDC power supply operation.
- RS-232 or RS-422 serial interface with multiple baud rates.
- Supports 4 or 8 ProScale™ linear measurement encoders.
- Provides position update of all eight channels every 100 milliseconds.
- Robust aluminum mounting enclosure: 130mm W x 105mm D x 45mm H.
- Positional data preformatted into ASCII strings.
- Programmable data packet checksum operation.

Additional details in *ProMUX Family* manual



Pro RF

The Pro-RF™ system consists of a base module and a remote module that communicate over a bi-directional RF interface.

The Remote module provides the data acquisition functions. It accepts 1 ProScale or Mitutoyo SPC output as input and relays the information via RF link to the Base module.

The Base module communicates to a host PC via RS-232 operating at 57,600 Baud.

The system can support up to 32 remote modules up to 100 meters away for each base module.

Base Module

RF-1 Module

Interface/Input :	DB9 Female RS-232 Interface	Mitutoyo SPC
RF Frequency:	916 MHz (USA), 2.4GHz (EU)	916 MHz (USA), 2.4GHz (EU)
RF Power Output:	0dbm (1mW) typical	0dbm (1mW) typical
Data Transmission:	Data packet w/security & checksum (Both)	
Power Supply:	9 VDC plug-in supply (provided)	NiMh batteries/Wall Plug
Weight:	5 ounces (22 grams)	7 ounces (31 grams)
Dimensions:	5.3" (135mm), 3.35" (85mm) 1.5" (38mm)L,W,H	4.25" (108mm), 2.60" (66mm), 1.14" (29mm) L,W,H

Additional details in *ProMUX Family* manual



Analog Interface Unit

The Analog Interface Unit (AIU) is designed to provide an analog signal output that is proportional to the current position being displayed on a ProScale linear measurement system. The interface provides a DC signal range from 0 to 5 volts or 0 to 10 volts depending on configuration. This offers a simple integration between a ProScale™ linear measurement system and a PLC or other process control system.

The interface incorporates a 12-bit Digital-to-Analog converter to generate the analog output. This provides 4096 discrete steps of resolution over the configured measuring range. This can offer a measurement displacement resolution of .001" over a 4-inch range of motion

Dimensions:	2.75" (70mm) wide x 3.38" (86mm) high x 2.27" (57.6mm) deep. (Uses 35mm DIN rail mount.)
Power:	8 to 24 VDC, 100 mA maximum.
Input:	Synchronous serial BCD (SPC)
Output:	0 to 5 or 0 to 10 VDC, 60mA

PRODUCT REGISTRATION

Fill out for your records and
FAX to Accurate Technology @ +1.828.654.8824 or
Register on line at www.proscale.com

Name _____

E-Mail _____

Company _____

Address _____

Address _____

City _____

State/Region _____

Zip/Postal Code _____

Country _____

Purchased From: _____

Purchased When: _____

ProScale Serial Number:

This manual is available at www.proscale.com

Accurate Technology, Inc.

270 Rutledge Rd. Unit E

Fletcher, NC 28732 USA

800 233-0580 • 828-654-7920

Fax 828-654-8824

www.proscale.com

customerservice@accurate-technology.com

Please register your product at

<http://www.proscale.com/registration.htm>