

# Accurate

TECHNOLOGY INC.

*Linear Digital Measuring Systems*

## LED Readout



**Installation & Operation**

---

## WARRANTY

Accurate Technology, Inc. warrants the ProScale Systems against defective parts and workmanship for 1 year commencing from the date of original purchase. Upon notification of a defect, Accurate Technology, Inc., shall have the option to repair or replace any defective part. Such services shall be the customer's sole and exclusive remedy. Expenses incidental to repair, maintenance, or replacement under warranty, including those for labor and material, shall be borne by Accurate Technology, Inc. (Including freight or transportation charges during the first 30 days).

Except as expressly provided in this warranty, Accurate Technology, Inc. does not make any warranties with respect to the product, either expressed or implied, including implied warranties of merchantability or fitness for a particular purpose, except as expressly provided in this agreement.

Accurate Technology, Inc. shall not be liable for any special, incidental, or consequential damages or for loss, damage or expense directly or indirectly arising from the customer's use of or inability to use the equipment either separately or in combination with other equipment, or for personal injury or loss or destruction of other property, or from any other cause.

To request repair work, (either warranty qualified parts or not) contact Accurate Technology, Inc. directly by phone, fax, or e-mail. A Returned Merchandise Authorization (RMA) number is required before returning a product for repair.

### **SAFETY WARNING**

**Before installing Readout on any machinery:**

**Turn off machine and LOCK-OUT POWER.**

---

# Table of Contents

|                                   |                            |           |
|-----------------------------------|----------------------------|-----------|
| <b>SECTION 1</b>                  | <b>GENERAL INFORMATION</b> | <b>4</b>  |
| Introduction .....                |                            | 4         |
| About This Manual .....           |                            | 4         |
| About the Readout .....           |                            | 5         |
| Readout Specifications .....      |                            | 5         |
| <b>SECTION 2</b>                  | <b>INSTALLATION</b>        | <b>6</b>  |
| Mounting the Readout .....        |                            | 6         |
| Initial Set-up .....              |                            | 6         |
| Electrical Connections.....       |                            | 6         |
| Reading Direction.....            |                            | 7         |
| Linear Scaling .....              |                            | 7         |
| Maintenance .....                 |                            | 7         |
| <b>SECTION 3</b>                  | <b>OPERATION</b>           | <b>8</b>  |
| Keypad Functions .....            |                            | 8         |
| MODE.....                         |                            | 8         |
| + (PLUS) .....                    |                            | 8         |
| 0 (ZERO).....                     |                            | 8         |
| – (MINUS) .....                   |                            | 8         |
| ABS / INC .....                   |                            | 8         |
| Offset Locking .....              |                            | 9         |
| Segment Adjustment.....           |                            | 9         |
| Displayed Measurement Units ..... |                            | 9         |
| Programmable Output.....          |                            | 9         |
| RS-485 Bus Commands .....         |                            | 10        |
| System Programming .....          |                            | 11        |
| Programming Parameters.....       |                            | 12        |
| <b>SECTION 4</b>                  | <b>MISCELLANEOUS</b>       | <b>15</b> |
| Frequently Asked Questions.....   |                            | 15        |

## Introduction

This LED Digital Readout is one of many Digital Readouts available for use with ProScale® Measuring Systems.

ProScale digital measuring systems are affordable precision electronic devices for making linear measurements with speed and accuracy. ProScale consists of a [SCALE](#), an [ENCODER](#) (also called READHEAD) and a [DIGITAL READOUT](#) (DRO).

This Readout supports ProScale Models [150](#), [250](#), [180](#), [280](#), [380](#) and [580](#).

## About This Manual

This manual includes Operating and Programming information for:

### **1/8 DIN Red LED In-Panel Mounted Digital Readout with Firmware version 3.000 or higher**

(Firmware version is displayed on power-up, ie **P3 . 000**)

**This manual DOES NOT include installation information for any other ProScale product.**

---

## About the Readout

- Two independent absolute measurement modes (M1 and M2) with programmable incremental mode (M3). Incremental mode can be programmed as:
  - Incremental mode with offset adjustment.
  - Third independent absolute mode.
- Programmable offsets for both M1 and M2 absolute modes and M3 incremental mode.
- Programmable to display millimeters or decimal inches.
- Offset lockout in both incremental and absolute modes.
- Offset programming disable via system programming.
- System configuration using keyboard programming.
- Programming lockout capability using jumper selection.
- Program functions stored in non-volatile memory (EEPROM).
- RS-485 communication bus allows up to 32 individual readouts to be connected on single twisted pair cable.
- Programmable scaling factor (.00001 to 9.99999).
- Programmable scale direction for sign correction.
- Programmable upper and lower limits with relay output.
- Multi-stage transient voltage protection.

## Readout Specifications

|                               |                                       |       |
|-------------------------------|---------------------------------------|-------|
| <b>Display Range:</b>         | $\pm 999.999$ in; or $\pm 9999.99$ mm |       |
| <b>Resolution:</b>            | .1inch                                | .1mm  |
|                               | .01inch                               | .01mm |
|                               | .001inch                              | .01mm |
|                               | .0005inch                             | .01mm |
| <b>Repeatability:</b>         | .01mm; .001in                         |       |
| <b>Size:</b>                  | 1/8 DIN (4" W x 2" H x 3" D)          |       |
| <b>Operating Power:</b>       | 14-24VDC @ 50mA max                   |       |
| <b>Operating Temperature:</b> | 32 to 120°F, 0 to 50°C                |       |
| <b>Output:</b>                | RS485                                 |       |

### Mounting the Readout

A cutout should be made in the panel that is 45mm x 90mm (3.5 x 1.75 inches). Mounting tabs supplied with the readout will hold it in place

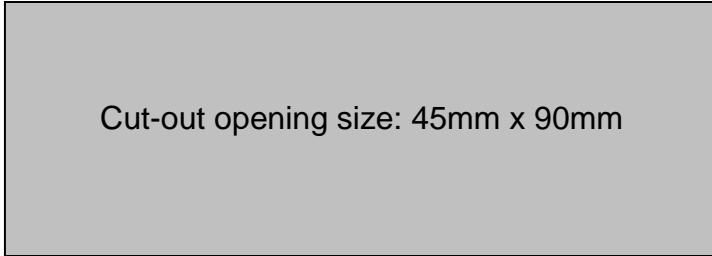

### Initial Set-up

#### Electrical Connections

This illustration shows all of the electrical connections to the ProScale LED readout. Power supply voltage is connected at terminals 1 (plus) and 2 (ground). RS-485 bus is connected to terminals 3 (plus) and 4 (minus). Limit output (optional) is connected to terminals 5 and 6.

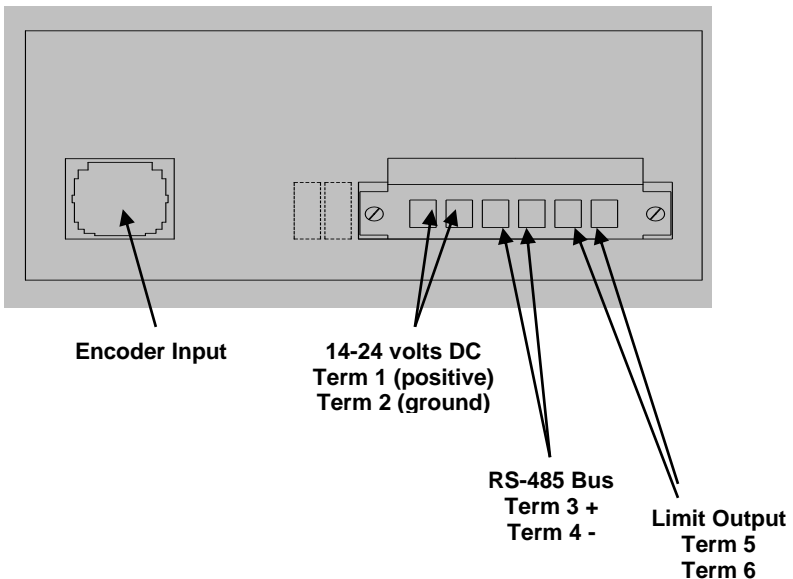

---

## Reading Direction

Once the system has been put into operation, if the direction of readings, (positive or negative values) is opposite the desired direction, the Readout programming may be changed to correct the direction.

[See Programming Parameter \(Pr5\).](#)

## Linear Scaling

The Readout has the ability to “scale” the actual measurement. This function is useful when the actual measurement must be multiplied or divided before being displayed. Care should be taken when using this function since invoking it will cause the unit to display a reading different than the actual measured value.

This function has a range of: 0.0001 to 99.9999 allowing the actual measured value to be multiplied or divided in very small or very large increments.

[See Programming Parameter \(Pr8\).](#)

## Maintenance

ProScale is designed to operate in a dry environment with non-conductive debris such as plastic or sawdust. The system should be cleaned of excess debris when necessary. Do not use any liquid lubricants on the scale assembly, as this may impede the encoders ability to operate properly and will attract other contaminants to the scale.

## Keypad Functions

### MODE

Activates the following functions depending on operating state:

- Selects absolute M1 or M2 modes or incremental M3 mode of operation during normal use.
- Press and hold for offset lock.
- Advances to next programming option while in programming mode.
- Acts as a "SHIFT" key to execute special operations:
  - Mode and **0** = Programming Mode entry and exit.
  - Mode and **+** = Add segment in multi-segment mode.
  - Mode and **-** = Subtract segment in multi-segment mode.

### + (PLUS)

- Adds to position offset value in normal use.
- Increments value of programming option while in program mode.

### 0 (ZERO)

- Sets the current displayed position to the DATUM value programmed. M1 = [Pr 1](#), M2 = [Pr 2](#), M3 = [Pr 3](#) (when used as an ABS coordinate system). The factory default value = 0.0000.

### - (MINUS)

- Subtracts from position-offset value in normal use.
- Decrements value of programming option while in program mode.

### ABS / INC

The independent absolute measurement modes M1 and M2 are used to display a position from a fixed reference point on a machine or coordinate system. The **PLUS**, **ZERO** and **MINUS** keys can be used to apply a position offset while the offset LOCK feature is not enabled.

The INC coordinate system can be operated in one of two modes:

- Automatic offset adjustment
- Third coordinate system similar to ABS M1 and M2

In automatic offset adjustment, an offset is programmed using the Plus, Zero and Minus keys (assuming LOCK is not enabled). Each single depression of the **MODE** key causes the programmed offset to be re-displayed as the current position on the scale. Pressing the **MODE** key twice within 2 seconds will return the display back to the ABS M1 mode of operation.



---

When programmed as a third independent absolute coordinate system, the incremental mode M3 operates exactly like ABS M1 and M2 modes. This can be useful in applications where independent coordinate systems are needed.

### **Offset Locking**

After approximately 2 seconds, the LED will flash if offsets are unlocked or glow steady if the offsets are locked. If offset change has been disabled in the programming mode ([Pr 6](#)), ABS mode and INC mode will always be in the locked state. Pressing the **MODE** key will have no effect.

### **Segment Adjustment**

If multi-segment mode has been enabled (ProScale M150 & 250 with measuring ranges longer than 17 inches), pressing and holding the **MODE** key along with either the **PLUS** or **MINUS** key will adjust the segment offset by +/- one segment length for each key depression. This feature is disabled if LOCK mode is on.

### **Displayed Measurement Units**

This function is selected via programming option [Pr 4](#) and can be set to millimeters or decimal inches. See the **System Programming** section for additional details.

### **Programmable Output**

The ProScale LED readout provides a low current output relay that will be activated whenever the value of absolute coordinate system M1 exceeds the user defined limits. An independent upper and lower limit exists for this functionality and can be accessed via the programming mode. This output is limited to .5A @ 125 VAC/ 1A @ 12VDC.

**See Programming Parameters** [Pr 11](#), [Pr 12](#), [Pr 13](#), [Pr 14](#), [Pr 15](#)

---

## RS-485 Bus Commands

The ProScale LED readout can be queried for its current position and status data via the RS-485 two-wire bus. Commands are issued using ASCII data transmitted in a packet form. The position query command (from host) is shown below:

See Programming Parameters [Pr 16](#), [Pr 17](#), [Pr 18](#)

| <u>Byte #</u> | <u>Definition</u>                         |
|---------------|---|
| 1             | Readout Address (ASCII 1 through ASCII b) |
| 2             | Position Query Command (ASCII A)          |
| 3             | Data Bytes To Follow (ASCII 0)            |

The LED readout will respond with the following string:

| <u>Byte #</u> | <u>Definition</u>  |
|---------------|--|
| 1             | Echo of display address (ASCII 1 through ASCII b)                                |
| 2             | Number of data bytes to follow (ASCII : 10 bytes)                                |
| 3             | Current coordinate system (ASCII 0 = M1, 1 = M2, 2 = M3)                         |
| 4             | Units mode (ASCII 0 = mm, 1 = inches)  |
| 5 – 12        | Position data in ASCII. Position data based on the currently selected resolution |
| 13            | Carriage return character, value = 13 decimal or 0x0D in hex.                    |

The readout expects individual characters to be received no more than 100 milliseconds apart. A minimum inter-character time should be no less than 3 milliseconds. If the inter-character time exceeds 100 milliseconds, the data packet will be ignored.

The readout will begin sending the requested position data within 30 milliseconds of a valid query command.

The word format is 8 data bits, no parity and 1 stop bit.

---

## System Programming

Several functions of this digital readout are user programmable. The following instructions describe what features are available and how to change the system's factory defaults to customize the readout for your application.

The keys have multiple functions. Timing, which is how long a key is depressed, and the combination of the keys pressed is important. This manual uses the term "*momentarily*" to describe a key press of typically less than 1 second. Whereas "*press and hold*" is used imply a key press of typically longer than 1.5 seconds. As an example; when using a PC keyboard to type a CAPITAL letter you would "*press and hold*" the SHIFT key and "*momentarily*" depress the appropriate letter key.

The "*function*" associated with the readout key pressed is sometimes executed on the key *RELEASE*, not the key *DEPRESS*. This is important since some keys execute different functions based on how long they are depressed. These key operations, once tried, quickly become intuitive.

Programming can be *Disabled* by moving the jumper located on the circuit board near the input connector to pins 2 and 3 (away from the connector) and *Enabled* by moving the jumper to pins 1 and 2 (toward the connector) All program parameters are maintained in non-volatile memory.

To enter programming mode, *press and hold* the **MODE** key and then *momentarily* press and release the **0** (zero) key. (The **MODE** key must be held for approximately 1 second before the depression of the **0** key).

Once in programming mode, The LED will briefly display: **PG on** (Programming On), then **Pr 1**, (indicating Programming Parameter #1) for about 1 second, then It will display parameter value

To change the current value of the parameter, press the **PLUS** or **MINUS** key to increase or decrease the displayed value. Each parameter has a limited range that cannot be exceeded by additional key presses of the **PLUS** or **MINUS** key.

Press the **ZERO** key to revert to the factory default setting for that parameter.

To move to the next programming parameter, momentarily press the **MODE** key. Parameters are numbered 0 through 14. When the last parameter has been reached, pressing the **MODE** key again will restart the parameter list at 0.

To exit programming mode, *press and hold* the **MODE** key and then *momentarily* press and release the **0** (zero) key.

**NOTE:** The readout will automatically exit programming mode after 60 seconds of no key activity.

---

## Programming Parameters

The Digital Readout Programming Parameters are listed below. Values in [ ] are the range of values available for that Parameter. Factory defaults values are shown in **Bold Red**.

- Pr1 – Datum preset for M1** [0.00]  
Sets the value measurement mode M1 will be forced to when the **ZERO** (0) key is pressed.
- Pr2 – Datum preset for M2** [0.00]  
Sets the value measurement mode M2 will be forced to when the **ZERO** (0) key is pressed.
- Pr3 – Datum preset for M3** [0.00]  
Sets the value measurement mode M3 will be forced to when the **ZERO** (0) key is pressed.
- Pr4 – Measurement Units** [0,1]  
0 = Millimeters  
1 = Inches
- Pr5 – Encoder Direction** [0,1]  
Changes the sign operation on the readout to alter which direction measurements are increasing or decreasing.
- Pr 6 – Key Lockout** [0 or 1]  
This parameter controls the operation of the +, - and datum keys. If enabled, (set to 1), these keys will not function (M1, M2, M3 LEDs remain ON). This prevents accidental changes when depressing these keys during normal operation.
- Pr 7 – Display Resolution** [1, 2, **3** or 4]  
This parameter sets the number of places to the right of the decimal point on the display. The Readout will auto-range to the next resolution if the value is too large to be displayed in the current resolution but is displayable in an alternate resolution.  
A value of **1** will display x.x.  
A value of **2** will display x.xx  
A value of **3** will display x.xxx (inches only)  
A value of **4** will display x.xxxx (inches only)

- 
- Pr 8 – Scaling** [0.00001 to 9.99999, **1.00000**]  
This parameter sets a linear multiplier correction factor in the Readout that is applied to the actual measurement prior to any offsets and then the adjusted measurement is displayed on the LED. This is useful, for instance, if you would like to display half, double, or any other value that can be achieved by multiplying the amount of actual movement by the value of the parameter setting.
- Pr 9 – ProScale Compatibility** [0 or **1**]  
This enables or disables compatibility with long ProScale ABS systems. Disable [set to **0**] for all ProScale 150-10, 180, 280, 380 and 580 systems.  
Enabled [set to **1**] for ProScale Model ABS systems longer than 16 inches (Model 150-18 and all Model 250 systems).
- Pr 10 – M3 Operation.** [0 or **1**]  
Configures the operation of the third coordinate system (M3).  
0 = standard ABS (Absolute)  
1 = Incremental mode
- Pr 11 – Use Limits.** [**0** or 1]  
Enables or disables the use of soft limits. If enabled, a message on the LED is displayed when the measuring system is operating outside the programmed (Pr 12 & Pr 13) position limits.  
0 = off  
1 = on
- Pr 12 –Lower Limit.** [+ 999.999in , + 9999.99mm]  
References the M1 absolute coordinate system and activates the output if the value of M1 decreases below this value.  
**Default = 0.000**
- Pr 13 –Upper Limit** [+ 999.999in , + 9999.99mm]  
References the M1 absolute coordinate system and activates the output if the value of M1 increases above this value.  
**Default = 5.000 inches, (127mm)**
- Pr14 – State of the Output signal** [**0** or 1]  
When M1 position is within the limits set in Pr12 and Pr13:  
0 = The output terminals are closed  
1 = The output terminals are open

---

**Pr 15 –Output Signal Operation.**

[0 or 1]

Selects the signal output operation.

0 – No output.

1 = Monitor limits

**Pr 16 – RS-485 Bus address**

[1 to 32]

This value identifies the address of the readout when used on a multi-point bus.

**Pr 17 – Bus Mode**

[0 or 1]

0 = poll for data.

1 = data is streamed at the encoder sampling rate.

**Pr 18 – RS-485 Bus baud rate**

[0, 1, 2, 3]

0 = 1200 baud

1 = 2400 baud

2 = 9600 baud

3 = 19200 baud

**Frequently Asked Questions****What does “no Enc” mean?**

If the Encoder is off the Scale, or the Encoder cable is unplugged from the Readout, an “no Enc” will appear on the Display. To clear error:

1. Be sure the Encoder is on the Scale and properly oriented.
2. Unplug the connector from the Readout for one second.  
Reconnect the Encoder cable to the Readout.

**Can I mount the scale/encoder without the connector link/guide clip?**

The connector link and guide clip serve to provide an accurate method of transferring the movement of the moving part to the Encoder or Scale, while also absorbing any stresses that may occur. If they are not used, the warranty could be voided.

**The Readout displays numbers but they seem to be random.**

Be sure the Encoder is oriented correctly on the Scale. One end of the Scale is black. Be sure that the arrow on the Encoder is pointed in the correct direction.

---

**Thank you for choosing a ProScale Product,**

**IT WAS PROUDLY MADE IN THE USA**



**Accurate Technology, Inc.**

270 Rutledge Rd. Unit E

Fletcher, NC 28732 USA

828-654-7920

[www.proscale.com](http://www.proscale.com)

*Please [register](#) your ProScale product*

**P/N 800-1095-001, Rev190808, Copyright © 2019,  
Accurate Technology, Inc. All rights reserved.**