

# Accurate

TECHNOLOGY INC.

*Linear Digital Measuring Systems*



*ProPanel-HD shown with optional transmitter and steel brace.*

**SERIAL #** \_\_\_\_\_

## ProPanel-HD

(Systems with Firmware version 4)

---

## **WARRANTY**

Accurate Technology, Inc. warrants the ProScale Systems against defective parts and workmanship for 1 year commencing from the date of original purchase. Upon notification of a defect, Accurate Technology, Inc., shall have the option to repair or replace any defective part. Such services shall be the customer's sole and exclusive remedy. Expenses incidental to repair, maintenance, or replacement under warranty, including those for labor and material, shall be borne by Accurate Technology, Inc. (Including freight or transportation charges during the first 30 days).

Except as expressly provided in this warranty, Accurate Technology, Inc. does not make any warranties with respect to the product, either expressed or implied, including implied warranties of merchantability or fitness for a particular purpose, except as expressly provided in this agreement.

Accurate Technology, Inc. shall not be liable for any special, incidental, or consequential damages or for loss, damage or expense directly or indirectly arising from the customer's use of or inability to use the equipment either separately or in combination with other equipment, or for personal injury or loss or destruction of other property, or from any other cause.

To request repair work, (either warranty qualified parts or not) contact Accurate Technology, Inc. directly by phone, fax, or e-mail. A Returned Merchandise Authorization (RMA) number is required before returning a product for repair.

---

**READOUT SERIAL #** \_\_\_\_\_

**DATE OF MANUFACTURE** \_\_\_\_\_

**FACTORY CONFIGURED PARAMETERS WHICH ARE SPECIFIC TO THIS GAGE:**

<b>Programming control</b>	<b>Value</b>
PARAMETER 2 (Reading direction)	1 (positive)
PARAMETER 11 (Available display units)	2 (no fractions)
PARAMETER 13 (Linear Correction Value)	
PARAMETER 14 (ProScale Technology)	0 (Inductive)
PARAMETER 30 (Number of offsets used)	
PARAMETER 31 (Offset Value #1)	
PARAMETER 32 (Offset Value #2)	
PARAMETER 33 (Offset Value #3)	
PARAMETER 39 (Non-Linear correction used?)	1 (yes)
PARAMETER 40 (Non-Linear correction Interval)	5.0000 inches
PARAMETER 41 (Temperature correction enabled?)	1 (yes)

See [www.proscale.com/700-1600-246](http://www.proscale.com/700-1600-246) for more details about these settings.

---

## Table of Contents

<b>INTRODUCTION</b> .....	<b>5</b>
<b>SPECIFICATIONS</b> .....	<b>6</b>
<b>CALIBRATION</b> .....	<b>6</b>
<b>INITIAL SET-UP</b> .....	<b>7</b>
<b>OUTSIDE MEASURING</b> .....	<b>8</b>
<b>INSIDE MEASURING</b> .....	<b>9</b>
<b>HOLE-TO-HOLE MEASUREMENTS</b> .....	<b>10</b>
<b>EDGE TO HOLE MEASUREMENTS</b> .....	<b>11</b>
<b>COMPARING DIAGONALS</b> .....	<b>12</b>
<b>GENERAL MAINTENANCE</b> .....	<b>13</b>
<b>BATTERY REPLACEMENT</b> .....	<b>13</b>
<b>PRIMARY KEY FUNCTIONS</b> .....	<b>14</b>
<b>SUPPLEMENTAL KEY FUNCTIONS</b> .....	<b>15</b>
<b>WHAT DO ALL THE SYMBOLS MEAN?</b> .....	<b>16</b>
<b>SPC PORT, SPECIAL MODES, AUTOMATIC ON/OFF</b> .....	<b>18</b>
<b>PROGRAMMING MODE</b> .....	<b>19</b>
<b>COMMON ERROR MESSAGES</b> .....	<b>20</b>
<b>ACCESSORIES</b> .....	<b>21</b>
<b>FREQUENTLY ASKED QUESTIONS</b> .....	<b>22</b>

---

## Introduction

This manual includes operation and use information for ProPanel-HD systems that use a ProScale General Purpose Enhanced Readout with operating firmware (F/W) of 4.000C and higher.

(The firmware version is displayed on power-up, i.e. P4.020C.)

***NOTE: Some pictures used in this manual may not represent your actual product's colors. The terms ProPanel, ProPanel-HD and ProPanel-HD-E are used interchangeably.***

ProPanel™ is a general-purpose portable measuring tool. It is ideal for making inside, outside, and corner-corner measurements. In addition, edge-to-hole and hole-to-hole measurements are possible with the optional [Cone Set](#). ProPanel-HD has been designed using high quality anodized aluminum extrusion and machined parts to provide the best accuracy and repeatability over a wide variety of environments.

The measurement system used for ProPanel-HD is based on the ProScale® Model 590 Digital Measuring System.

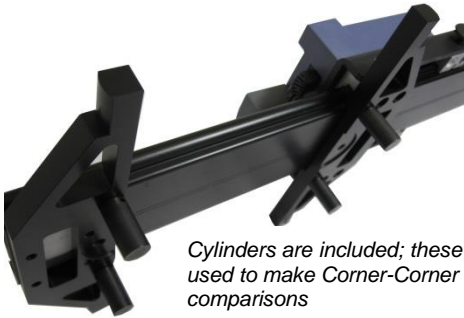

*Cylinders are included; these are used to make Corner-Corner comparisons*

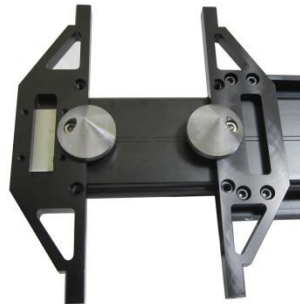

*Optional Cone Set is used to make Hole-Hole and Edge-Hole measurements*

---

## Specifications

<b>Measuring Range:</b>	Stock sizes to 195 inches range
<b>Accuracy:</b>	$\pm .005$ in ( $\pm .13$ mm) (When beam is properly supported)
<b>Resolution</b>	Inches: 1, 2, 3, or 4 decimal places Millimeters: 1 or 2 decimal places Centimeters: 1, 2, or 3 decimal places Fractions: $1/16^{\text{ths}}$ , $1/32^{\text{nds}}$ , or $1/64^{\text{ths}}$
<b>Repeatability</b>	.001in or .01mm or .001cm
<b>Operating Temp:</b>	32 to 120°F (0 to 51°C)
<b>Max. Slew Rate:</b>	80 inches/sec. (2000mm/sec)
<b>Power:</b>	1 CR123 (3V Lithium battery)
<b>Output Format:</b>	Mitutoyo Digimatic® SPC

## Calibration

Each ProPanel-HD system is calibrated at factory when initially built. Systems should be checked at least once per year for accuracy, and serviced as needed. If you see a **NoCo** message, the readout is trying to show a dimension that is outside the range of calibration. Close jaws and press the DATUM key. If **NoCo** message does not clear, consult factory for assistance.



## Initial Set-up

In most instances, the initial parameters such as a reference point, measurement units, and resolution will be factory set. (See page 2 for these.)

**UNITS:** To change the measurement units, press the UNITS Key.

The readout will cycle thru:

- Decimal Inches
- Fractions – 16ths of inch
- Fractions – 32<sup>nd</sup> of inch
- Fractions – 64<sup>th</sup> of inch
- Millimeters (or centimeters if enable)

**DATUM:** Close the jaws together and verify the readout shows zero. Press the DATUM key if needed. The keypad can be locked if desired; this prevents accidental presses of the PLUS, MINUS, or DATUM keys from affecting accuracy.

**CUSTOMIZE:** Many operations/features of the ProPanel system can be configured to suit best way you will use the gage. See Programming Mode section for details about the numerous controls/settings available.

---

## Outside Measuring

Use the ProPanel-HD like a handheld caliper or T-square. Close the jaws against the edges of the item being measured, keeping the jaws as square to the edges as possible, and read the result on the readout.



Tips:

- Ensure the beam is not sagging during measurements.
- Try to use the full width of the jaws wherever possible.



---

## Inside Measuring

1. Press the **F1** key on the keypad. A small number **1** will appear just above the dimension.
2. The readout is now showing the **Inside measurement**.  
Note: This offset value is factory programmed (see page 2), but can be changed if needed
3. Using the upper or lower tips of the jaws, measure the inside dimension of interest, and read the result on the readout.

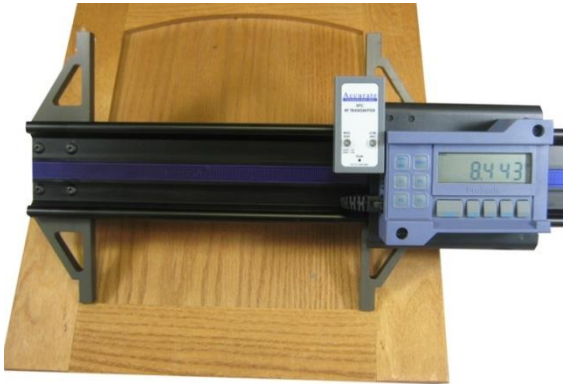

Note: Videos showing how these measurements are made are posted at web site: [www.proscale.com/propanel/](http://www.proscale.com/propanel/)

---

## Hole-to-Hole Measurements

(Using optional Cone Kit parts)

1. Close the jaws together and momentarily push the DATUM key.
2. Install both full cones as shown using the supplied 3/16" wrench.
3. Press the F1 key until the #2 superscript appears on the screen.



### Notes:

- The tips of the cones are even with the edges of the jaws, so the value displayed is the same as for outside measuring.
  - Hole-to-hole measurements less than 1.5" are not possible.
4. Open the jaws and place the cones into the holes in the part. A slight "wiggling" of the ProPanel will ensure the cones self-center into the holes.



5. Read the Hole-to-Hole distance on the readout.
6. If you need to recalibrate with the cones installed:
  - a. Press the DATUM key to clear the readout.
  - b. Close the moving carriage so the edge of the cones touch.
  - c. Press the F1 key until the #2 superscript appears.
  - d. The reading should equal 1.500 inches.

Note: Videos showing how these measurements are made are posted at web site: [www.proscale.com/propanel/](http://www.proscale.com/propanel/)

---

## Edge to Hole Measurements

1. Close the jaws and push the DATUM key.
2. Install a full cone onto the moving jaw, and the half cylinder onto the fixed jaw. For the most accurate measurements, be sure the flat edge of the half cylinder is installed co-planer to the flat edge of the measurement jaw.
3. Press the F1 key until the #3 superscript appears on the screen.  
Notes:
  - The tips of the inserts are even with the edges of the jaws, so the value displayed is correct.
  - Edge-to-hole measurements less than 0.75" are not possible.
4. Open the jaws and place the fixed jaw with the half cylinder against the outside edge of the part. Then place the full cone into the hole.
5. Read the Hole-to-Edge distance on the readout.
6. If you need to recalibrate with these inserts installed:
  - a. Press the DATUM key to clear the readout.
  - b. Close the moving jaw so the cones touch.
  - c. Press the F1 key until the #3 superscript appears.
  - d. The reading should equal 0.750 inches.

Note: Videos showing how these measurements are made are posted at web site: [www.proscale.com/propanel/](http://www.proscale.com/propanel/)

---

## Comparing Diagonals

1. Remove Cone Kit parts if they are installed.
2. Mount the four steel cylinders to the bottom of the jaws. Tip: Be sure the outsides of the cylinders are tangent to the jaw faces.
3. Place the pins on the fixed jaw around one corner of the part.



4. Open the moving carriage and place pins on the moving jaw around opposite corner.
5. Press the ABS/INC key to set a temporary zero point. (Depending on the readout's configuration, you may need to press and hold the ABS/INC key for a few seconds.)
6. Rotate the part or the ProPanel gage, and measure the other diagonal. The displayed reading is the differential between the diagonals.
7. Press the ABS/INC key to return to the absolute mode.

Note: Videos showing how these measurements are made are posted at web site: [www.proscale.com/propanel/](http://www.proscale.com/propanel/)

---

## General Maintenance

ProPanel-HD will operate in a dry environment with non-conductive debris such as sawdust, plastic, metal dust, and small amounts of water splash with no adverse effects. The system should be cleaned of excess debris when necessary to prevent premature damage to the electronic scale and encoder/sensor. The digital readout should be cleaned periodically with compressed air to remove any dust on the lens and keys.

All mounting fasteners should be checked occasionally for tightness. Occasionally check parallelism of the jaws by measuring a piece of paper between the upper tips of the jaws, then between the lower tips of the jaws. A variation larger than 0.05mm (0.002 inches) requires adjustment. If the carriage becomes difficult to move (and the lock/thumbscrew is not tightened), clean the scale. Locate and remove any burrs which may have developed on the aluminum beam. Do not use any liquid lubricants on the ProPanel-HD system.

## Battery Replacement

When the battery in the digital readout needs to be replaced, the battery icon will only show one bar, or you will see a “**B FAIL**” message on the screen.

Remove the screws in the upper right and lower left corners of the readout. Pull the cover off. Remove the old battery. Install a new CR123 (or equivalent) battery noting the proper orientation. Replace the cover and screws. Tip: Be careful to avoid touching parts of the circuit board not related to the battery.



## Primary key functions



What happens on a **QUICK PRESS** of each key?

Key	Action
ON/OFF	The readout turns on or off.
UNITS	The units change. <i>Note: Available units can be restricted with custom programming settings.</i>
PLUS	The displayed value is increased one unit.
DATUM	The displayed value is set to the programmed datum value. <i>Note: This value is zero by default, but it can be customized to be any value.</i>
MINUS	The displayed value is decreased one unit.

What happens if a **KEY IS HELD DOWN**?

Key	Action
ON/OFF	Nothing
UNITS	Nothing
PLUS	The displayed value increases faster each 2 seconds.
DATUM	After 4 seconds, the battery voltage is displayed. After 7 seconds, the readout's temperature is displayed.
MINUS	The displayed value decreases faster each 2 seconds.

### Key Combinations:

For these actions, **press and hold the first key**, then quickly **press and release** the second key. (*This action is the same as making a capital letter on a computer; the first key acts like SHIFT.*)

Press and hold	Then quickly press and release	Action
ON/OFF	UNITS	LOCK (or unlock) the keypad.
ON/OFF	DATUM	Enters or exits the programming mode.*
UNITS	PLUS	Adds one segment to displayed value. ( <i>Models 150/250 only.</i> )
UNITS	MINUS	Adds one segment to displayed value. ( <i>Models 150/250 only.</i> )

\*Requires programming jumper to be in position 1; see page 13.

## Supplemental key functions

The digital readout supplied with ProPanel has a supplemental keypad that allows additional features to be used. See below for functions of these keys:



Key	Quick press action	Press and hold action
ABS/INC	When in ABS mode, no action.  When in INC mode, the INC value is reset.	When in ABS mode, toggles readout to INC mode.  When in INC mode, toggles readout back to ABS mode.
SEND	The currently displayed value is sent to the SPC port.	<i>None</i>
F1	An offset value is applied. <i>(If offset feature is enabled in the programming menu).</i>  Also used to store compensation point data in Enhanced Readouts.	<i>None</i>
F2	Used to set compensation end point for Enhanced Readouts.	<i>None</i>
F3	Turns Monitor mode on or off. <i>(If monitor feature is enabled in the programming menu.)</i>  Starts editor for Go/NoGo editor. <i>(If Go/NoGo feature is enabled.)</i>	<i>None</i>
F4	Turns HOLD mode on or off. <i>(If hold feature is enabled in the programming menu.)</i>  Edits values in Go/NoGo editor. <i>(If Go/NoGo feature is enabled.)</i>	<i>None</i>



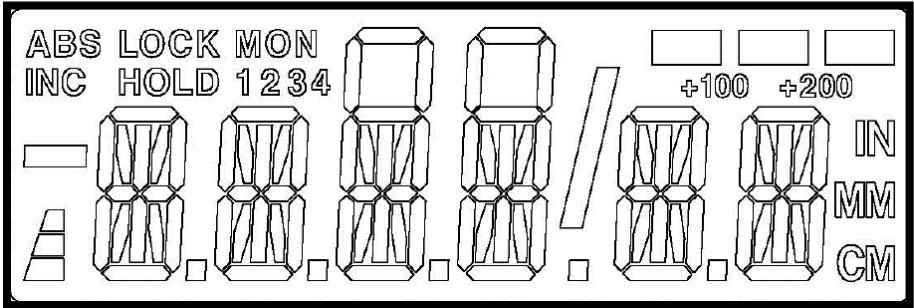

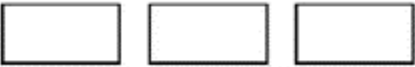
## What do all the Symbols mean?



Symbol	Meaning
ABS	The digital readout is operating in Absolute measurement mode.
INC	The digital readout is operating in Incremental (temporary) mode. Press and hold ABS/INC key 3 seconds to go back to ABS mode.
LOCK	The readout is in LOCK mode. This prevents loss of calibration if PLUS, MINUS, or DATUM keys are pressed. See page 6 for key combination to turn this off.
HOLD	The readout's display is frozen. When this feature is enabled, press F4 key to turn on/off.
MON	Monitor mode (drift alarm) is turned on. When this feature is enabled, press F3 key to turn on/off.
1 2 3 4	When any of these are displayed, the readout is adding a programmed offset value to the primary dimension. Offsets are useful for applications with multiple fixed data points.
	These are used with the 16 <sup>th</sup> and 32 <sup>nd</sup> fractional inch modes. Each bar represents an extra 1/64 <sup>th</sup> long/heavy on the dimension.



## Symbols (continued):

	When using fractions over 99 inches, one (or both) of these will light to show a value over 100 inches. For example: measurement is 205 5/16. The readout will show <b>5 5/16</b> and turn on the <b>+200</b> indicator.
	Minus sign. Turns on when a negative value is displayed.
	Battery level indicator. When all 3 bars are lit, the battery is good. When only bottom bar is lit, a new battery is needed soon.
	Vinculum – used in fractions mode to separate numerator from denominator.
	Units indicator. IN is for INCHES or fractions. MM for millimeters. CM for centimeters. (Press UNITS key to change.)

---

## SPC Port, Special Modes, Automatic on/off

**SPC PORT:** Position data can be requested by external devices, or sent from the digital readout by pressing the SEND key.

**SPECIAL MODES:** The digital readout has several special modes/features that can be enabled to add more features. These include:

Mode/feature	Function
Offsets	Allows the readout to track up to 5 reference positions at the same time.
Monitor	Allows the readout to watch for unintended motion/drift.
Hold	Allows the current measurement to be frozen.
Go, NoGo	Allows the readout to act as a Go, NoGo gage (up to 32 positions can be stored).
Limits	Allows readout to alert operator if measurement is outside of a preset zone.
Input device mapping	Controls how a pushbutton or footswitch works with the readout.
Output controls	Choose how the output of the readout works.
Compensation	Linear, Temperature, and Non-Linear compensations are all set at factory.
Programming Mode	Where you customize several dozen parameters to get the readout working exactly as you want.

Consult the Complete User Guide at [www.proscale.com/700-1600-246](http://www.proscale.com/700-1600-246) or contact factory for assistance with any of these special modes.

**Auto Off:** To prolong battery life, the readout has a built-in timer that turns off the readout after a period of no activity. The default timer is 15 minutes.  
*(The timer can be changed using the programming mode, parameter Pr12.)*

**Auto On:** Any motion of the carriage greater than 0.004 inches will wake up the readout and restart the Auto Off timer.  
*(The amount of motion required can be changed using the programming mode, parameter Pr5.)*

---

## Programming Mode

Many features of the readout can be customized (plus additional tools can be enabled) using the programming menu. For information and videos about using the programming menu, go to [www.proscale.com/700-1600-246](http://www.proscale.com/700-1600-246)

Parameter number	What it does	Default value
Pr1	Sets the DATUM key value.	0.000
Pr2	0 = default reading direction 1 = reversed reading direction	0
Pr3	0 = +, - and DATUM keys are operative. 1 = These keys are disabled (LOCK).	0
Pr4	The resolution for decimal readings.	3
Pr5	Motion needed to wake up the readout.	0.004 inches
Pr6	Do fractions round up or down?	0 (round down)
Pr7	Resolution of 4 <sup>th</sup> decimal place (inches)	1 (.0005" resolution)
Pr11	Controls available units modes.	0 (All units)
Pr12	Auto-off timer (in minutes)	15
Pr13	Linear multiplier	1.00000
Pr14	Encoder compatibility	1 (Absolute scale)
Pr15	LCD contrast adjustment	27
Pr16	Final linear multiplier	1.00000
Pr22	ABS/INC key operation	0 (2 seconds)
Pr23	Supplemental keys enabled?	3 (All enabled)
Pr24	Monitor/hold, Go/NoGo features	0 (Disabled)
Pr25	Go/NoGo values to save	0 (None)
Pr26	Drift Monitor tolerance	.01 inches
Pr27	Limits modes used	0 (Not used)
Pr28	Lower limit value	0.000
Pr29	Upper limit value	5.000 inches
Pr30	Offset additions to use	0 (None)
Pr31	First offset value	0.5000 inches
Pr32	Second offset value	2.0000 inches
Pr33	Third offset value	3.0000 inches
Pr34	Fourth offset value	3.0000 inches
Pr35	External input operation mapping #1	0 (No function)
Pr36	External input operation mapping #2	0 (No function)
Pr37	Polarity for Output functions	0 (Normally open)
Pr38	Output Function used	0 (None)
Pr39 *	Turn on non-linear compensation	0 (Disabled)
Pr40 *	Non-linear correction step value	5.000 inches
Pr41 *	Temperature compensation on/off	0 (Off)
Pr44 *	Coefficient used for temperature	150

---



## Common Error messages

The following is a list of the most common error codes and their meaning. For additional help with any error message, consult factory.

<b>Message</b>	<b>What it means</b>
<i>no Enc</i>	There is not an encoder connected to the readout, or the connected encoder has a fault.
<i>no Pos</i>	The readout has not been calibrated yet.
<i>b fail</i>	The battery in the readout needs to be replaced immediately.
<i>f fail</i>	The readout cannot display fractional values larger than 399 63/64 inches.
<i>P fail</i>	The battery in the readout needs to be replaced immediately. Check programming values after new battery is installed.
<i>LOCK</i>	The keypad is LOCKed, but an attempt was made to change the calibration. Unlock keypad to fix, see page 14.
<i>P LOCK</i>	The keypad is LOCKed, but an attempt was made to change the calibration. Change programming parameter Pr3 to fix. (See <a href="http://www.proscale.com/700-1600-246">www.proscale.com/700-1600-246</a> for more details.)
<i>no oFF</i>	Offsets are disabled, but an attempt was made to apply an offset value.
<i>MON flashing</i>	Monitor mode is turned on, and the system is out of the allowable position.
<i>no Co</i>	Non-linear compensation is enabled, but there is no look-up data for the displayed measurement.
<i>uL, LL</i>	Limits mode is turned on, and a limit has been exceeded.

## Accessories

The ProPanel-HD readout outputs Mitutoyo Digimatic® SPC. This signal can be converted to USB or RS232 using a ProRF Wireless SPC System.

<p>The <a href="#">Cone Kit</a> includes 2 full cones plus a half cylinder (all steel). These parts can be attached to ProPanel's jaws to provide edge-to-hole and hole-to-hole measurement ability.</p>	 The image shows the Cone Kit components: a half-cylinder steel part with a hole, a long L-shaped steel pin, and two full circular steel cones, each with a hole in the center.
<p>The measurement from a ProPanel can be transmitted to a remote computer using the <a href="#">SPC Data Set</a>. The small transmitter module plugs into the readout and uses 802.15 signaling to the receiver. The receiver connects to computer on USB, and is compatible with almost any software.</p>	 The image shows the SPC Data Set components: a white rectangular receiver unit with a small display and buttons, and a small black transmitter module with a USB connector.
<p>The measurement from a ProPanel can be transmitted to a nearby computer using the <a href="#">SmartCable</a>. This unit connects ProPanel to a USB port on your computer. Data enters the computer as if it came from a keyboard.</p>	 The image shows the SmartCable, which consists of a blue rectangular adapter unit connected to a black cable with a USB connector on one end and a ProPanel connector on the other.

---

## Frequently Asked Questions

### What does no Enc mean?

The carriage has been moved too fast, or  
The sensor and the readout are not communicating.  
To clear:

1. Be sure the moving carriage is on the electronic scale.
2. Unplug the encoder from the readout for five seconds.
3. Connect the encoder to the readout.

### What does b FAIL mean?

When the readout displays this message, it means the battery voltage has dropped to a level where reliable operation is no longer possible. Install a new battery to clear this message.

### What does P FAIL mean?

When the readout displays this message, it means the battery voltage has dropped to a level where reliable programming is not possible. Install a new battery to clear this message.

### The readout does not change, or changes very little, as it moves.

1. The readout is in the HOLD mode.
2. The linear scaling factor is set very low.

### The readout alternately shows “no Co” and a measurement.

The readout has non-linear compensation enabled, and:

1. The position of the encoder is outside the calibrated range.  
*Move the encoder to a position within the calibrated range*
2. The system's datum has changed.  
*Place the moving carriage against the fixed jaw, then press DATUM key.*
3. The readout is in INC mode.  
*Return to ABS mode and verify system is datumed.*



---

**Thank you for choosing a ProScale Product,**

**IT WAS PROUDLY MADE IN THE USA**



**Accurate Technology, Inc.**

270 Rutledge Rd. Unit E

Fletcher, NC 28732 USA

1-828-654-7920

[www.proscale.com](http://www.proscale.com)

**P/N 800-1090-105**

**Copyright © 2020, Accurate Technology, Inc. All rights reserved.**