

Accurate

TECHNOLOGY INC.

Linear Digital Measuring Systems

ProStop



ProStop Serial # _____

Installation & Operation

WARRANTY

Accurate Technology, Inc. warrants the ProScale Systems against defective parts and workmanship for 1 year commencing from the date of original purchase. Upon notification of a defect, Accurate Technology, Inc., shall have the option to repair or replace any defective part. Such services shall be the customer's sole and exclusive remedy. Expenses incidental to repair, maintenance, or replacement under warranty, including those for labor and material, shall be borne by Accurate Technology, Inc. (Including freight or transportation charges during the first 30 days).

Except as expressly provided in this warranty, Accurate Technology, Inc. does not make any warranties with respect to the product, either expressed or implied, including implied warranties of merchantability or fitness for a particular purpose, except as expressly provided in this agreement.

Accurate Technology, Inc. shall not be liable for any special, incidental, or consequential damages or for loss, damage or expense directly or indirectly arising from the customer's use of or inability to use the equipment either separately or in combination with other equipment, or for personal injury or loss or destruction of other property, or from any other cause.

To request repair work, (either warranty qualified parts or not) contact Accurate Technology, Inc. directly by phone, fax, or e-mail. A Returned Merchandise Authorization (RMA) number is required before returning a product for repair.

SAFETY WARNING

**Before installing ProStop on any machinery:
Turn off machine and LOCK-OUT POWER.**

PRE-CONFIGURED PARAMETERS FOR THIS PROSTOP

READOUT SERIAL # _____

PARAMETER 2 (Reading Direction) _____

PARAMETER 13 (Linear Multiplier) _____

This value has been set at the factory to provide the best accuracy for your system. Changing this value or the Readout WILL degrade the accuracy.

PARAMETER 14 (ProScale Technology) **0**

TABLE OF CONTENTS

SECTION 1	GENERAL INFORMATION	5
INTRODUCTION		5
ABOUT THIS MANUAL.....		5
SPECIFICATIONS.....		6
PROSTOP PARTS		7
Scale.....		7
Encoder		7
Readout		7
Stop Assembly.....		7
Fence.....		7
Quick Set.....		7
Exploded View.....		8
SECTION 2	PROSTOP INSTALLATION	9
MOUNTING THE FENCE ASSEMBLY		9
INSTALL THE STOP ASSEMBLY		10
CALIBRATION.....		10
DIGITAL STOP OPERATION		11
QUICKSET OPERATION		11
SECTION 3	READOUT OPERATION	12
INITIAL SET-UP		12
KEY TIMING.....		13
KEY FUNCTIONS		14
On/Off Key		14
Units Key.....		14
Plus (+) & Minus (-) Keys.....		15
Datum Key		15
FUNDAMENTAL READOUT FUNCTIONS.....		16
Auto on/off.....		16
Reading Direction.....		16
Resolution		16
Measurement Units		17
Key Lock		17
Linear Scaling		17
ADVANCED READOUT FUNCTIONS		18
Absolute / Incremental.....		18
Send.....		19
Offset Addition.....		19
ADVANCED PROGRAMMING FUNCTIONS.....		20
Measurement Accumulator		21
CIRCUIT BOARD JUMPERS.....		22
MAINTENANCE.....		22

SECTION 4	PROGRAMMING THE READOUT	23
KEY TIMING		23
RESETTING PARAMETERS TO DEFAULT		23
ENTER PROGRAMMING MODE		24
NAVIGATING PROGRAMMING MODE:		24
PROGRAMMING PARAMETER SUMMARY		25
EXIT PROGRAMMING MODE.....		26
PROGRAMMING PARAMETER DETAILS.....		26
Pr1 – Datum Key		27
Pr2 – Direction		27
Pr3 – Key Lockout.....		27
Pr4 – Readout Resolution		27
Pr5 – Movement to Wake Readout		27
Pr11 – Readout Measurement Units		28
Pr12 – Readout Auto-Off Time.....		28
Pr13 – Linear Compensation.....		28
Pr14 – ProScale Compatibility.....		28
Pr22 – ABS/INC Key Operation		29
Pr23 – Auxiliary Keypad Enable.....		29
Pr24 – Special Functions		29
Pr25 – Special Function		29
Pr26 – Drift Monitor Tolerance		29
Pr27 – Upper/Lower Limits.....		29
Pr28 – Lower Limit		30
Pr29 – Upper Limit		30
Pr30 – Offset Addition		30
Pr31 – Offset 1		30
Pr32 – Offset 2		30
Pr33 – Offset 3		30
Pr34 – Offset 4		30
Pr35-Pr44.....		30
FREQUENTLY ASKED QUESTIONS		31

Introduction

[ProStop](#) is a general purpose Digital Stop & Fence System. It is ideal for use on Miter saws, Chop Saws, Radial Arm Saws or any other application where a moveable stop along a fixed back fence is desired. It has been designed using high quality extruded and machined parts to provide the best accuracy and repeatability.

ProStop is not intended for use as a Dimensional Measuring System for Quality Control. For QC/QA applications See [QUALITY CONTROL](#) products on www.proscale.com.

About This Manual

This manual includes installation and operation information for [ProStop](#) systems using a ProScale [General Purpose Readout](#) (pictured below and supplied as standard equipment on ProStop systems) with operating firmware (FW) of 3.1xxC and higher.

(The Firmware version is displayed on power-up, i.e. P3.100C)



Specifications

Measuring Range¹:

ProStop-4	up to 50 inches	(1.3 meters)
ProStop-8	up to 94 inches	(2.4 meters)
ProStop-10	up to 118 inches	(2.9 meters)
ProStop-20	up to 234 inches	(5.9 meters)

Accuracy²: +/- 0.010 inches (0.25 mm)

Resolution

.1inch	.1mm	.1cm	or
.01inch	.01mm	.01cm	or
.001inch	.01mm	.001cm	or
.0005inch	.01mm	.001cm	or
1/16inch	1/32inch	1/64 inch	

Repeatability: .001in or .01mm or .001cm

Display Range: ± 999.999 in; ± 399 63/64 in
± 9999.99 mm; ± 999.999 cm

Operating Temp: 32 to 120°F 0 to 51°C

Max. Slew Rate: 60 inches/sec. (1500mm/sec)

Power: 1 CR123 3V Lithium battery
(or equivalent)

¹ MEASUREMENT range is approximately 6 inches *shorter* than the PHYSICAL length of the aluminum fence extrusion.

² Maximum observed error over the entire measuring range.

ProStop Parts

Scale

ProStop systems use [Inductive Series 1 Incremental Technology](#). The Scales have a repeating “bar” pattern on a colored laminate bonded to an aluminum extrusion.



Encoder

Encoders for ProStop have black housings.. The Encoder orientation on the scale can be reversed without adverse affect to operation.



Readout

ProStop can operate with any of several different [Digital Readouts](#), but is supplied with a [General Purpose](#) readout unless otherwise specified. It is powered by 1 CR123 or equivalent battery.



Stop Assembly

A dual locking flip stop assembly with a detachable, reversible 45/90 degree accessory plate. This assembly includes the Readout and the Encoder.



Fence

The extruded aluminum fence provides support for the material to be cut, and the mounting of the Digital Stop assembly and the Digital Scale.



Quick Set

Two Quick Sets are included with ProStop. These are useful for indexing one or two positions (cut sizes) that are very common and used often.



Exploded View

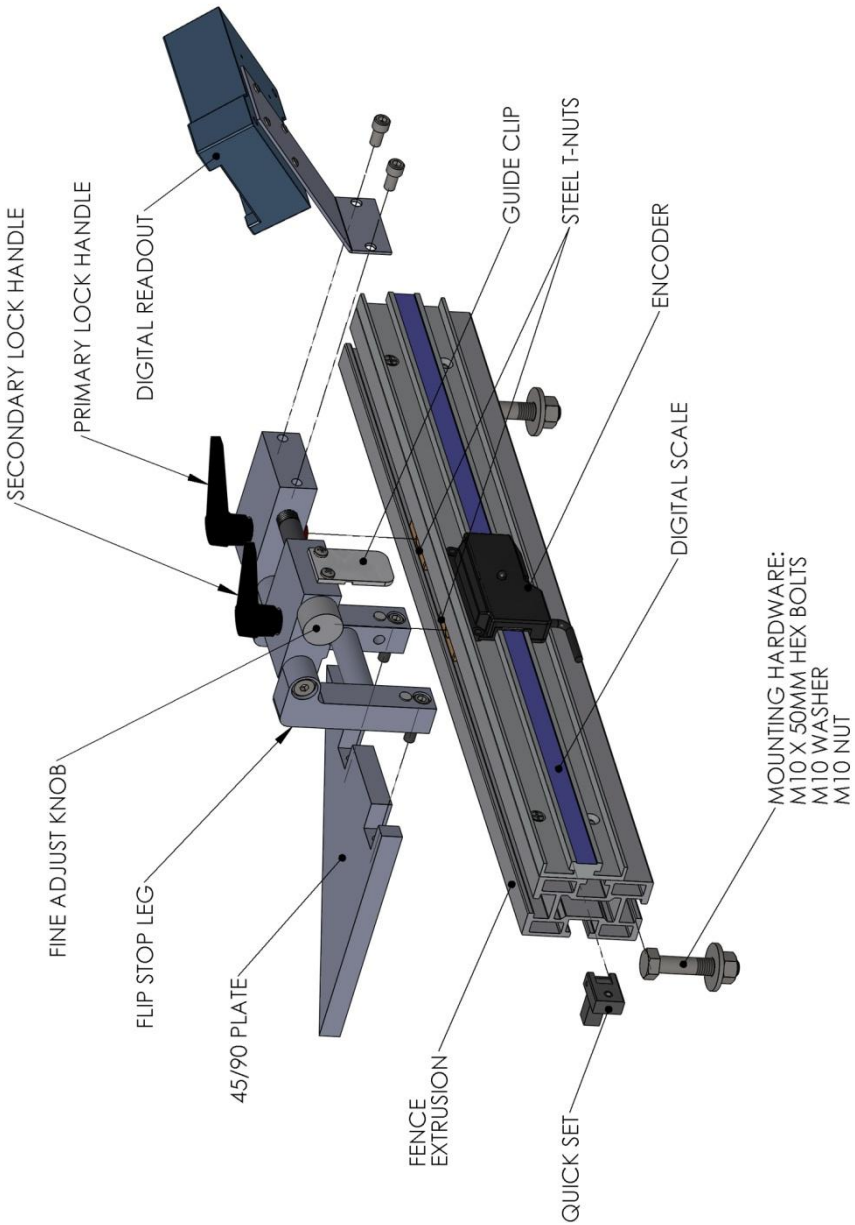

Mounting the Fence Assembly

1. Align the Fence Assembly adjacent to the saw.
2. Mark a line on the table top, along the front edge of the Fence.
3. Remove the Fence assembly and mark a second line 7/8 inch (22mm) behind the first line (this is the centerline of the Fence).
4. Drill mounting holes (at least 2) into the tabletop along the centerline of the Fence.
5. Insert the supplied 10mm bolts through the table from the top. Install the supplied hex nuts onto the bolts 1 or 2 threads deep at this time.
6. Slide the Fence, end first, back into place capturing the bolt heads in the bottom T-slot of the Fence Assembly. After the Fence is in place and aligned to the saw, tighten all nuts.

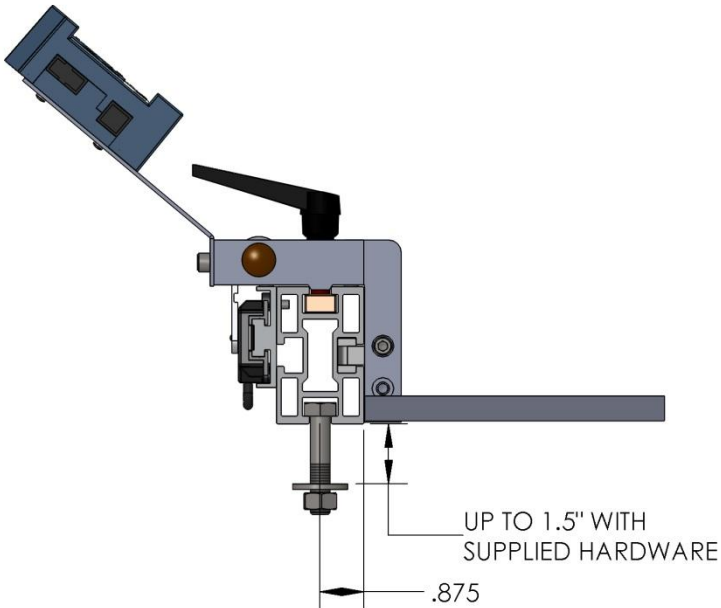

Install the Stop Assembly



1. Loosen the Stop Assembly lock handle(s) and slide the stop onto the Fence, guiding the lock nut into the upper Fence slot.
2. Carefully slide the encoder onto the Scale and position it under the Guide Clip on the Stop Assembly. The post on the top of the Encoder should snap into the slot on the inside of the Guide Clip.
3. Attach the Readout bracket (and Readout) to the Stop Assembly.
4. Plug the Encoder into the Readout.
5. Move the stop assembly left to right and note if the readings increase or decrease. Depending upon the installation, left vs. right in-feed, it may be necessary to program the Readout to reverse the reading direction. (Refer to [Reading Direction](#) in Section 3).
6. To install the 45/90 stop plate:
 - a. Remove the round spacer from the bottom of the flip stop assembly.
 - b. Slide the 45/90 plate into place on the flip stop assembly and tighten the supplied installation bolts. (The plate can be installed with the 45 or 90 degree edge facing the saw, depending on your application.)

Calibration

1. Check to be sure installation of all parts is complete, all fasteners are secure and the Encoder is plugged into the Readout.
2. Cut a sample part of arbitrary length using the ProStop. (Keep this piece for future reference and calibration, See Programming Parameter [Pr1](#)).
3. Measure the length of the part with the most precise measuring tool available (i.e. digital calipers).
4. Without moving the Stop position, press the Datum key to zero the Readout. See also Programming Parameter [Pr1](#)
5. Use the **+** key (or **-** key) on the Readout to scroll to the measurement obtained in Step 3. (The longer the **+** or **-**, key is held down, the faster the reading will scroll.)
6. When the correct reading is reached, lock the DRO. This prevents accidental loss of calibration. (Refer to [Key Lock](#) in Section 3)

-
7. Re-calibrate if necessary (ie after changing the saw blade) using the piece saved in Step 2 and adjusting the + or – keys or using the Programmed DATUM key.

Digital Stop Operation

1. Slide the Stop to the approximate position.
2. Turn the [Primary Lock](#) handle until it is locked, then turn the [Fine Adjust](#) knob to position the Stop to the exact location. (Each full turn is 0.050 inches.) Lock the [Secondary Lock](#).



QuickSet Operation

For frequently used cut sizes, position the Stop Assembly to the first frequently cut size and install a Quick Set assembly into the front slot of the Fence Assembly against the Stop Assembly and tighten the set screw. Repeat until all Quick Sets have been installed.



Orientation of the Quickset is important since it will only allow the Stop Assembly to pass by in one direction but not the other offering a quick reference location. If the Stop does not move freely past the Quick Set, remove, reverse and reinstall it.

The Stop Assembly can now be positioned quickly and accurately.

NOTE: Quick Sets are designed for quick re-positioning of the Stop assembly. They are not intended to be used as an additional Stop.



Initial Set-up

In most instances it will be desirable to set some initial parameters such as a measurement units and resolution for your ProStop application.

Measurement Units

The measurement units that are displayed (inch, mm, cm) are selected with the [UNITS](#) Key.

Reading Direction

The direction of the reading as the ProStop system is moved is programmed using Programming Parameter [Pr2](#).

Resolution

The resolution of the displayed units is programmed using Programming Parameter [Pr4](#).

Additional [Set-up](#) items MAY include:

[Auto On/Off](#)
[Key Lock](#)

NOTE: Some of the Initial Set-Up parameters for your ProStop have already been preset for you at the factory. Please see [page 2](#) of this manual for a list of these parameters.

Key Timing

Several keys on the Readout have multiple functions. The function executed when the key is depressed is dependent on how long the key is depressed. Therefore, how long the key is depressed is important.

This manual uses the term “*Momentarily*” to describe a key depression of less than .8 seconds, and “*Press and Hold*” to describe a key depression of longer than 1 second.

	<i>Momentarily</i>	<i>Press & Hold</i>
How long a key is pressed?	Less than .8 seconds	More than 1 second
When is the key function executed?	On key release	While holding

For *Momentarily* key operations, the Function is executed when the key is released.

For *Press & Hold* operations, the Function is executed after the key has been depressed for the prescribed amount of time.

See the chart below for a summary of the functions performed by these keys:



For a video demonstration of KEY TIMING click [HERE](#).

	<i>Momentarily</i>	<i>Press & Hold</i>
On/Off Key	Turns Readout power On or Off	No effect
Units Key	Cycles through measurement units: inches, fractions, mm	No effect
Plus (+) Key	Increments displayed value	Increments faster
Datum Key	Forces displayed reading to programmed Datum value	After 6 seconds displays battery voltage After 9 seconds displays Temperature
Minus (-) Key	Decrements displayed value	Decrements faster

Key Functions

On/Off Key



Momentarily depress the **ON/OFF** key to turn the Readout on or off. (The Readout Firmware version displays for two seconds at power-on.)

Units Key

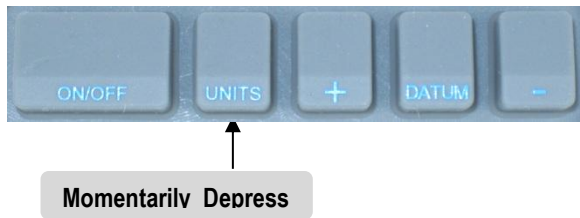

Momentarily depressing the **UNITS** key will cycle through decimal inches, fractions and millimeters (or centimeters). To set the measurement modes that are displayed when pressing the **UNITS** key use [Programming Parameter \(Pr11\)](#).

When the Readout is in 1/16 or 1/32 inch fraction mode, a series of “bars” may appear in the upper right corner of the LCD each representing 1/64th of an inch. (ie. When in 1/16 inch mode and three bars appear, the measurement displayed is rounded *down* to the closest 1/16 inch and each illuminated bar indicates an additional 1/64 of an inch of measurement.) For better resolution, switch to 1/32 or 1/64 mode.

In Fractions mode, when the measurement is greater than $+100$ $+200$ 99 63/64 inches, +100 and/or +200 will illuminate in the upper right portion of the LCD to indicate this amount must be added to the displayed reading. (ie: If the measurement is 154 5/8 inches, 54 5/8 and +100 will appear on the LCD, If the measurement is -307 23/64 inches, - 7 23/64, +100 and +200 will appear on the LCD.

Plus (+) & Minus (-) Keys

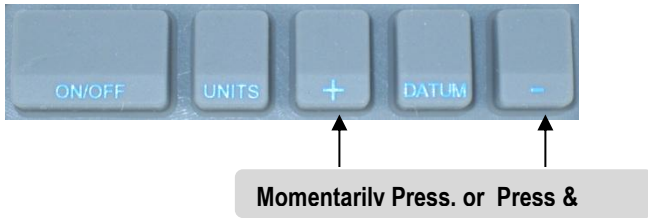

Momentarily depressing the **+** or **-** key will increment or decrement the current displayed value by one unit of measurement. (in, mm, cm or 1/64)
Press & Hold the **+** or **-** key to continue to increment or decrement the displayed value. The longer the key is depressed, the faster changes occur.

The **+** & **-** keys may be locked out to prevent accidental entries by using [key lock](#) and/or [Programming Parameter \(Pr3\)](#).

Datum Key



Momentarily depressing the **DATUM** key forces the Readout to a user programmed value. This can be zero or any other displayable value. Set the **DATUM** key value by programming [Parameter \(Pr1\)](#).

Press and Hold the **DATUM** key for 6 seconds to display the battery voltage.

Press and Hold the **DATUM** key for 9 seconds to display the temperature. The temperature is displayed in "F" or "C" based on the current units setting (Inch or Metric).

The **DATUM** key may be locked out to prevent accidental entries by using [key lock](#) and/or [Programming Parameter \(Pr3\)](#).

Fundamental Readout Functions

NOTE: All the functions of the standard ProStop Readout are included here. The functions that **DO NOT APPLY**, to ProStops are shown *Grayed Out*.

For more information on these functions:

See **OPERATION, LCD READOUTS** at: www.proscale.com/Manuals.htm.

Auto on/off

To prolong battery life, the Readout has a built-in function that turns off the Readout after a period of no movement or key activity. The Auto On/Off function is programmable from 0 (always on), to 240 (minutes) before entering sleep mode.

Press the **ON/OFF** key or move the measurement system to wake up the Readout. Any key press or system motion while the Readout is awake restarts the Auto On/Off timer. Use [Programming Parameter \(Pr12\)](#) to set this interval.

Reading Direction

If the direction of readings, (increasing vs. decreasing) is opposite the desired direction, use [Programming Parameter \(Pr2\)](#) to reverse the Reading Direction. (useful when left or right infeed operation is reversed)

Resolution

Four selectable display resolutions are available.

Fractional inches display mode is not affected by resolution changes.

.1in	.1mm	.1cm	or
.01in	.01mm	.01cm	or
.001in	.01mm	.001cm	or
.0005in	.01mm	.001cm	

Use [Programming Parameter \(Pr4\)](#) to set the displayed resolution.

Measurement data displayed is auto-ranging. This means the selected resolution may be temporarily overridden if the measurement displayed exceeds the maximum displayable value for the programmed resolution. The Readout will continue to automatically reduce the resolution to 1 decimal place or until an allowable resolution is achieved.

Inch Resolution	Maximum Value (Inches)
4 decimal places	99.9999
3 decimal places	999.999
2 decimal places	9999.99
1 decimal place	99999.9
Millimeter Resolution	Maximum Value (mm)
2 decimal places	9999.99
1 decimal place	99999.9

Measurement Units

The measurement units displayed on the Readout are user configurable. The table below provides a matrix for selecting the measurement units that may be displayed when pressing the **UNITS** key.

Use [Programming Parameter \(Pr11\)](#) to set this value.

Programming Parameter Pr 11 Value	Measurement Units Displayed
0	All inch units, and millimeters
1	Millimeters only
2	Decimal inches and millimeters
3	Decimal inches and centimeters
4	All inch units, and centimeters
5	Centimeters only
6	Decimal inches only

Key Lock

The Readout provides a function that can “lock-out” the position adjustment keys (**+**, **DATUM** & **-**) to prevent accidental changes of the displayed value.

To activate Key Lock: *Press and Hold* the **ON/OFF** key and, while pressing it, *Momentarily* depress the **UNITS** key, then release both keys. The word **LOCK** will be displayed in the upper left corner of the LCD.



When **LOCK** is displayed, the **+**, **DATUM** and **-** keys become inactive.

To de-activate the Key Lock: Press and Hold the **ON/OFF** key and, while pressing it, Momentarily depress the **UNITS** key, then release both keys.

Key Lock may also be enabled through Readout Programming. This method allows a more permanent Key Lock since programming can be disabled with a hardware jumper inside the Readout.

See [Programming Parameter \(Pr3\)](#) to enable this function.

Linear Scaling

This function is useful when the actual measurement must be multiplied or divided before being displayed on the Readout.

This function has a range of 0.0001 to 9.9999 allowing the actual measured value to be multiplied or divided in very small or very large increments.

See [Programming Parameter \(Pr13\)](#) for additional information.

This value has been set at the factory to provide the best accuracy for your ProStop system. Changing this value WILL degrade the accuracy.

Segment Offset

THIS FUNCTION DOES NOT APPLY TO PROSTOP SYSTEMS

For more information: See **OPERATION, LCD READOUTS** at:
www.proscale.com/Manuals.htm

Upper/Lower Limits

THIS FUNCTION DOES NOT APPLY TO PROSTOP SYSTEMS

For more information: See **OPERATION, LCD READOUTS** at:
www.proscale.com/Manuals.htm

Advanced Readout Functions

Absolute / Incremental

The Readout has two measurement indexes. One is called ABS (absolute) and the other INC (incremental).

The ABS measurement setting is designed to allow a user to set an origin point on the Readout referenced to a fixed or known position on the ProStop. The INC measurement setting is designed to take relative or incremental measurements from one point to another. The settings operate independently allowing separate position offsets to be programmed for ABS and INC. The origin, or known position of the measuring system is not lost when using the INC measurement mode and is recalled and displayed when the Readout is returned to ABS mode.



Absolute (ABS)

The Readout automatically enters ABS mode when power is first applied. This is indicated by **ABS** in the upper left corner of the LCD. While in ABS mode, all measurements are related to the current system reference point.

To enter INC (Incremental) mode:

Press and Hold the **ABS/INC** key for 3 seconds.

NOTE: To change the timing of this key to *Momentarily*, see [Programming Parameter \(Pr22\)](#).

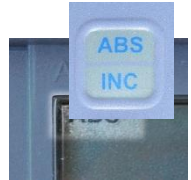

Incremental (INC)

While in the INC mode, **INC** is shown in the upper left corner of the LCD. When INC mode is initially entered, the displayed position will change to reflect a new reference point at the current position of the Encoder. This is typically a position of zero (**0.00**) but may be changed by using the **+** or **-** Key to enter an offset. Moving the Stop in either direction will display the distance moved from the initial INC starting point (plus any offset). To complete another incremental measurement from the new position, *Momentarily* press the **ABS/INC** key. The Readout will again change to zero (or the previously programmed offset). To return to the ABS mode, *Press and Hold* the **ABS/INC** key for 3 seconds.

Send

The Readout has an output port that may be used to send measurement to another device (i.e. a PC) via a wireless transmitter.



After connecting a transmitter to the 10 pin output connector on the Readout, the user may initiate the data transmission by momentarily pressing the **SEND** key. This will cause **Snd** to display on the Readout for 1 second to show activation of the send function (even if no device is attached to the Readout).

All inch modes are transmitted as decimal inches. All metric modes are transmitted as millimeters. The position data transmitted is typically the displayed position on the LCD, with the exception of when Special Function Mode is set to Measurement Accumulation or Statistics modes (See [Advanced Readout Functions](#)). In those modes, the displayed (or calculated) values are sent, NOT the current encoder position.

The data format and connector style of the output port is Mitutoyo [Digimatic](#). This is an industry standard that can be interfaced with most products including multiplexers & RS232 converters (See [Section 6: Accessories](#)).

Offset Addition

Offset addition allows values to be pre-programmed that are then added to the measurement, and the sum is displayed on the LCD. This function allows the user to switch from one reference point to another.

[See PROGRAMMING PARAMETERS \(Pr30, 31, 32, 33 & 34\)](#)

The ProStop Readout supports up to 4 user definable offsets that may be added to the ABS position.

[PROGRAMMING PARAMETER Pr30](#) enables or disables this function.

[PROGRAMMING PARAMETERS Pr31, 32, 33 & 34](#) are used to configure this function.

When enabled, the user can scroll through the active offsets by pressing the **F1** key. The numbers **1, 2, 3 or 4** will be displayed on the upper left part of the LCD with each press of **F1**. When no numbers are displayed, no offset addition is active.

When the number **1** is displayed in the upper left corner, Offset Addition Preset # 1 ([Pr31](#)) has been applied to the measurement and the result is now displayed on the LCD.



Similarly, when the number **2** is displayed in the upper left corner, Offset Addition Preset # 2 ([Pr32](#)) has been applied to the measurement.

When the number **3** is displayed, Offset Addition Preset 3 ([Pr33](#)) has been applied to the measurement, and when the number **4** is displayed, Offset Addition Preset 4 ([Pr34](#)) has been applied to the measurement and the result displayed.

1234

Advanced Programming Functions

Advanced Programming Functions allow the Readout to perform special tasks or invoke custom programming. These tasks interact with the F keys to perform functions related to a specific task or programming operation.

Note: The Advanced Functions configurable via **Pr24** are mutually exclusive of each other. The table below provides a summary of the functions available.

Programming Parameter Pr24 Value	Function
0	No Advanced Functions.
1	F3 = MON F4 = HOLD F2 = SPC delete
2	Go/No Go gauge operation
3	Measurement Accumulation
4	Statistics Mode

Note: When **PROGRAMMING PARAMETER Pr24** is set to **0**, the **F2, F3 & F4** keys are disabled and have no function. However, the **F1** key, used only for **Offset Addition**, is independently controlled by Pr30.

Set Programming Parameter **Pr24** = **1** to enable this function.

Monitor

THIS FUNCTION DOES NOT APPLY TO PROSTOP SYSTEMS

For more information: See **OPERATION, LCD READOUTS** at: www.proscale.com/Manuals.htm

Hold

THIS FUNCTION DOES NOT APPLY TO PROSTOP SYSTEMS

For more information: See **OPERATION, LCD READOUTS** at: www.proscale.com/Manuals.htm

Delete

THIS FUNCTION DOES NOT APPLY TO PROSTOP SYSTEMS

For more information: See **OPERATION, LCD READOUTS** at: www.proscale.com/Manuals.htm

Go/NoGo

THIS FUNCTION DOES NOT APPLY TO PROSTOP SYSTEMS

For more information: See **OPERATION, LCD READOUTS** at: www.proscale.com/Manuals.htm

Statistics

THIS FUNCTION DOES NOT APPLY TO PROSTOP SYSTEMS

For more information: See **OPERATION, LCD READOUTS** at: www.proscale.com/Manuals.htm

Measurement Accumulator

This Function allows multiple measurements to be made, and the sum displayed on the Readout.



SET PROGRAMMING PARAMETER **Pr24** = **3** to enable this function.

PROGRAMMING PARAMETER **Pr25** is used to configure this function.

F3 & F4 are used to execute this function.

1. Press the **F4** key to view any previous accumulator value.
The LCD will display **Accu** for 1 second followed by the total accumulated measurements. The display format for the accumulated total is controlled by both the currently selected measurement mode (**UNITS** key) and the Programming Parameter **Pr25**.
 - a. If **Pr25** is set to 0, and the Readout is in inch mode, (decimal or fractions), the accumulated total is displayed in Decimal Inches.
 - b. If **Pr25** is set to 0, and the Readout is in metric mode, (mm or cm), the accumulated total is displayed in mm.
 - c. If **Pr25** is set to any non-zero value, and the Readout is in inch modes, (decimal or fractions), the accumulated total is displayed as feet and inches. (fff ii) where f=feet and i = inches
 - d. If **Pr25** is set to any non-zero value, and the Readout is in metric mode, (mm or cm), the accumulated total is displayed as meters and millimeters. (MM mmm) where M=meters and m=millimeters.
2. Press the **F3** key to clear the accumulator.
The LCD will display **CLr** for 1 second. The DRO will return to the normal measuring mode.
3. To add a measurement to the accumulator, make the measurement and then press the **F3** key. The LCD momentarily displays **Add** to indicate that the measurement has been added to the accumulated total. Continue to add measurements by pressing the **F3** key as each measurement is made.
4. To view the accumulated total, press the **F4** key.
The following options are now available:
 - a. Press **F3** to clear the total and return to the measuring mode.
 - b. Press **F4** (DOES NOT clear the total) to return to the measuring mode.
 - c. Press **SEND** to transmit the accumulated total to the output port.

NOTE: This Function maintains a running sum of the measurements taken. Individual measurements in a series cannot be edited or deleted. If an error is made and an incorrect measurement is taken, the entire summation must be cleared and repeated. No rounding of inches or millimeters occurs when configured for feet/inches or meters/millimeters.

Circuit Board Jumpers

JP1 **FACTORY USE ONLY**

JP2 **FACTORY USE ONLY**

Position A ONLY

JP3 **Programming Lock-out**

Default = Position A

Front panel programming of the Readout can be enabled or disabled through the use of this circuit board jumper.

Front panel Programming is enabled when the shorting jumper is installed in position **A**. To disable Front panel Programming, install jumper on position **B**. When programming is disabled, user cannot access the programming functions via the front panel as described in the [Section 4: PROGRAMMING PARAMETERS](#). This provides a method of configuring the Digital Readout with specific parameters, and preventing unauthorized or accidental changes.

JP4 **Readout Power Selection**

Default = Position B

THIS FUNCTION DOES NOT APPLY TO PROSTOP SYSTEMS

For more information: See **OPERATION, LCD READOUTS** at: www.proscale.com/Manuals.htm

JP5 **Input/Output Selection**

Default = Position A

THIS FUNCTION DOES NOT APPLY TO PROSTOP SYSTEMS

For more information: See **OPERATION, LCD READOUTS** at: www.proscale.com/Manuals.htm

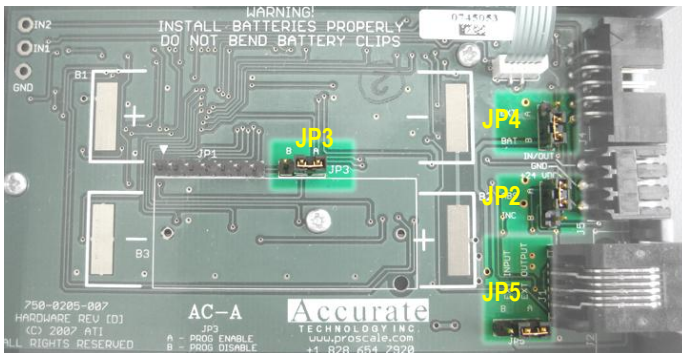

Maintenance

The fence extrusion should be cleaned of all debris frequently. The Readout should be cleaned periodically with compressed air to remove any dust on the lens and keys. All fasteners should occasionally be checked for tightness

Many functions of these Digital Readouts are user programmable and may need to be configured for different applications.

Key Timing

Several keys on the Readouts have multiple functions. The function that is executed when a key is depressed is dependent on how long the key is depressed. Therefore, how long the key is depressed is important. This manual uses the term “*Momentarily*” to describe a key depression of less than .8 seconds, and “*Press and Hold*” to describe a key depression of longer than 1 second.

	<i>Momentarily</i>	<i>Press & Hold</i>
How long a key is pressed?	Less than .8 seconds	More than 1 second
When is the key function executed?	On key release	While holding

For Momentary key operations, the Key Function is executed on release. For Press & Hold operations, the Key Function is executed after the key has been depressed for the prescribed amount of time.

Resetting Parameters to Default

To reset all programming parameters to their Factory Default settings:

1. Turn the Readout power off.
2. Insure [JP3](#) is in position A
3. *Press and Hold* the **ON/OFF** and **UNITS** keys for 10 seconds.

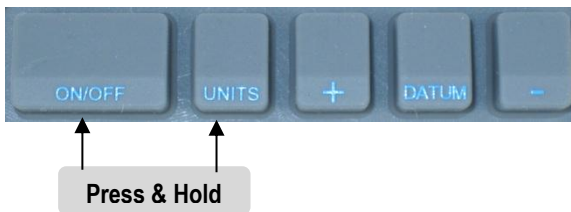

The Readout will:

1. Perform a full segment LCD test
2. Display the current firmware version
3. **Reset all programming parameters to factory default values. (not recommended unless instructed by factory technician)**
See [Programming Parameter Summary](#) for a list of Factory Defaults.
See Pg 2 for a list of factory preset parameters for this system.

Enter Programming Mode

Press and Hold the **UNITS** key while *Momentarily* pressing the **DATUM** key. The LCD will briefly display: **PG on** (Programming On). Release both keys. The LCD will then display **Pr 1**, (indicating Programming Parameter #1) for about 1 second, then display the value stored for **Pr1**.

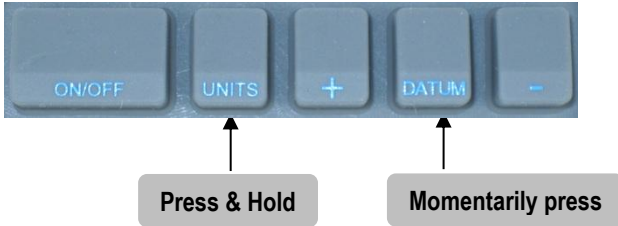

[Video demonstration](#)

Navigating Programming Mode:

To move up Parameter list:

Momentarily press the **UNITS** key to advance up through the Programming Parameter list. The Readout will display the Parameter number, then the current programmed value.



To move down Parameter list:

Press and Hold the **ON/OFF** key and *Momentarily* press the **UNITS** key to move backward through the Parameter list.



To Increase a Parameter value:

Momentarily press the **plus (+)** key while the Parameter value is displayed.



To Decrease Parameter value:

Momentarily press the **minus (-)** key while the Parameter value is displayed.



To Reset a Parameter value to the Factory Default setting:

Momentarily press the **DATUM** key while the Parameter value is displayed.



Programming Parameter Summary

The table below lists all available Readout Programming Parameters and values that will be restored when the Readout is [Reset To Factory Parameters](#).

Refer to [Page 2](#) for any parameters that may have been pre-set at the factory for your ProStop.

Parameter	Function	Range	Default
Pr1	DATUM	[0 to ± 999.999in] or [0 to ± 9999.99mm]	0
Pr2	Direction of Travel	[0 or 1]	0
Pr3	Key Lockout	[0 or 1]	0
Pr4	Readout Resolution	[1,2,3 or 4]	3
Pr5	Move to Wake Readout	[0.10 to 10mm]	0.10mm
Pr11	Readout Units	[0 to 6]	0
Pr12	Readout Auto-Off Time	[0 to 240]	15
Pr13	Linear Compensation	[0.00001 to 9.99999]	1.00000
Pr14	ProScale Compatibility	[0 or 1]	1
Pr22	ABS/INC Key Operation	[0 to 1]	0
Pr23	Auxiliary Keypad Enable	[0 to 3]	3
Pr24	Special Functions	[0 to 4]	0
Pr25	Special Function Variable	[0 to 16]	0
Pr26	Drift Monitor Tolerance	[.01 mm to 3048 mm] or [.001 in to 120 in]	.010in
Pr27	Upper/Lower Limits	[0 or 1]	0
Pr28	Lower Limit	[0 to ± 999.999in] or [0 to ± 9999.99mm]	0
Pr29	Upper Limit	[0 to ± 999.999in] or [0 to ± 9999.99mm]	5.000in
Pr30	Offset Addition	[0 to 4]	0
Pr31	Offset 1	[0 to ± 999.999in] or [0 to ± 9999.99mm]	.500in
Pr32	Offset 2	[0 to ± 999.999in] or [0 to ± 9999.99mm]	2.000in
Pr33	Offset 3	[0 to ± 999.999in] or [0 to ± 9999.99mm]	3.000in
Pr34	Offset 4	[0 to ± 999.999in] or [0 to ± 9999.99mm]	3.000in
Pr35	External Key Input 1	[0 to 11]	0
Pr36	External Key Input 2	[0 to 11]	0
Pr37	Output Polarity	[0 or 1]	0
Pr38	Output Function	[0 to 3]	0
Pr39	Non-Linear Compensation	[0 or 1]	0
Pr40	Non-Linear Interval	[0.5 to 10.0 in.]	5.000in
Pr41	Temperature Comp.	[0 or 1]	0
Pr44	Temperature Comp. Coef.	[10 to 999]	150

Exit Programming Mode

1. *Press and Hold* the **UNITS** key until the Readout displays **Pr x**
2. *Momentarily* press the **DATUM** key. The LCD will display **PG off**
3. Release both keys. The Readout will return to normal operation.

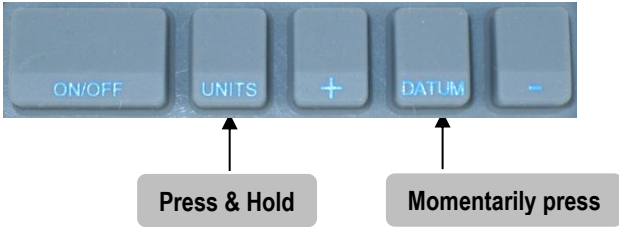

[Video demonstration](#)

NOTE: The Readout will automatically exit programming mode after 60 seconds of no key activity.

Programming Parameter Details

NOTE: Programming parameters are not sequentially numbered due to firmware differences between measurement systems and the provision for future enhancements, functions and custom features.

All of the available functions of the Standard ProStop Readout ([General Purpose](#)) are included in this section. The Programming Parameters that **DO NOT** apply to ProStop are shown **Grayed Out**. If a different Readout is used on your ProStop system, refer to the Operation Manual for that readout.

Programming Parameter Values in brackets [] represent the range of possible values available for that Parameter.

The Factory **Default Value** for each parameter is shown in **Bold Red**.

Pr1 – Datum Key [0 to ± 999.999in] or [0 to ± 9999.99mm]

The value that will be recalled on the Readout when the **DATUM** key is pressed. For ProStop operations this value could be set to some known, repeatable position determined during [calibration](#).

Default Value= 0.00

Pr2 – Direction of Travel [0 or 1]

This parameter controls the measurements (left vs. right in-feed) displayed on the readout when the Stop is moved.

Default Value = 0 May have been pre-set at factory. See page 2

Pr3 – Key Lockout [0 or 1]

This parameter can lock out the operation of the +, - and **DATUM** keys, preventing accidental changes to the Readout and ProStop calibration.

Default Value = 0

Pr 3 Setting	Key Action
0	+, - and Datum keys respond normally
1	+, - and Datum keys are locked

Pr4 – Readout Resolution [1, 2, 3 or 4]

This parameter sets the number of places to the right of the decimal point displayed on the Readout. When the Readout is in a decimal mode (in, mm or cm), it will auto-range to the next lower resolution if the value is too large to be displayed in the current setting but is displayable in a lower resolution.

Default Value = 3

Pr 4 Setting	Display Resolution
1	x.x
2	x.xx
3	x.xxx
4	x.xxxx

NOTES:

- Decimal inches have a maximum of 3 decimal places (4 places ± .0005).
- Millimeters have a maximum of 2 decimal places
- This option has no effect when displaying fractions.

Pr5 – Movement to Wake Readout [0.10 to 10mm]

This parameter sets the amount of Stop movement required to automatically wake up the Readout when it is turned off or in sleep mode.

Default Value = 0.10mm

Pr11 – Readout Measurement Units

[0 to 6]

This parameter controls the type of measuring units the ProStop displays when the **UNITS** key is pressed. The table below illustrates the possible combinations of measuring units that will be displayed by changing this parameter.

Default Value = 0

Pr 11 Setting	Displayable Units
0	All inch units and millimeters
1	Millimeters only
2	Decimal inches and millimeters
3	Decimal inches and centimeters
4	All inch units and centimeters
5	Centimeters only
6	Decimal inches only

Pr12 – Readout Auto-Off Time

[0 to 240]

This parameter changes the amount of time before the Readout turns off to conserve battery power. The value is the number of minutes of idle operation (no movement or key presses) before the readout turns off. When this parameter is enabled ($\neq 0$), pressing the **ON/OFF** key or movement of the Stop will wake up the Readout.

A value of '0' disables the Auto Off feature (the Readout is always on).

Default Value = 15 (minutes)

Pr13 – Linear Compensation

[0.00001 to 9.99999]

This parameter has been pre-set at the factory for **THIS** ProStop system. See page 2 of this manual for the value needed to optimize the accuracy of THIS system. **CHANGING THIS VALUE WILL COMPROMISE THE ACCURACY OF YOUR SYSTEM!**

Default Value = 1.000 PRE-SET AT FACTORY FOR BEST ACCURACY.

Pr14 – ProScale Compatibility

[0 or 1]

THIS FUNCTION DOES NOT APPLY TO PROSTOP SYSTEMS

For more information: See **OPERATION, LCD READOUTS** at:

www.proscale.com/Manuals.htm

Pr22 – ABS/INC Key Operation [0 or 1]

This parameter controls the amount of time the **ABS/INC** key needs to be pressed to enter the **INC**remental measuring mode.

Default Value = 0

Pr 22 Setting	Key press to enter INC remental mode
0	<i>Press and Hold</i> ABS/INC key (1.2 sec)
1	<i>Momentary depress</i> ABS/INC key (< 1 sec)

Pr23 – Auxiliary Keypad Enable [0 to 3]

The parameter controls the operation of the **ABS/INC** and **SEND** keys.

Default Value = 3

Pr 23 Setting	ABS/INC and SEND keys
0	Disable Both Keys
1	Enable abs/inc Key only
2	Enable send Key only
3	Enable Both Keys

Pr24 – Special Functions [0 to 4]

This parameter controls which Advanced Programming Function is active

Default Value = 0

Pr24 Setting	Advanced Readout Function
0	None
1	F3 = MON, F4 = HOLD, F2 = Delete
2	Go/NoGo
3	Measurement Accumulation
4	Statistics

Pr25 – Special Function [0 to 16]

The parameter may be used by a special function to customize it's operation. See Advanced Programming Function for instances when this parameter is used.

Default Value = 0

Pr26 – Drift Monitor Tolerance

THIS FUNCTION DOES NOT APPLY TO PROSTOP SYSTEMS

For more information: See **OPERATION, LCD READOUTS** at:

www.proscale.com/Manuals.htm

Pr27 – Upper/Lower Limits

THIS FUNCTION DOES NOT APPLY TO PROSTOP SYSTEMS

For more information: See **OPERATION, LCD READOUTS** at:

www.proscale.com/Manuals.htm

Pr28 – Lower Limit

THIS FUNCTION DOES NOT APPLY TO PROSTOP SYSTEMS

For more information: See **OPERATION, LCD READOUTS** at:
www.proscale.com/Manuals.htm

Pr29 – Upper Limit

THIS FUNCTION DOES NOT APPLY TO PROSTOP SYSTEMS

For more information: See **OPERATION, LCD READOUTS** at:
www.proscale.com/Manuals.htm

Pr30 – Offset Addition

[0 to 4]

This parameter Enables/Disables the use of the Offset Addition function. Pr31, Pr32, Pr33, and Pr34 set the value of the offsets to be added.

Default Value = 0

Pr30 Setting	Offsets Enabled
0	None
1	Offset 1 Enabled
2	Offsets 1 & 2 Enabled
3	Offsets 1, 2 & 3 Enabled
4	Offsets 1, 2, 3 & 4 Enabled

Pr31 – Offset 1 [0 to ± 999.999in] or [0 to ± 9999.99mm]

This value is added to the current measurement (or position) when: Pr 30 ≠ 0, and **1** is displayed in the upper left area of the LCD.

Default Value = .500 in. (12.7mm)

Pr32 – Offset 2 [0 to ± 999.999in] or [0 to ± 9999.99mm]

This value is added to the current measurement (or position) when: Pr 30 ≠ 0, and **2** is displayed in the upper left area of the LCD.

Default Value = 2 in. (50.8mm)

Pr33 – Offset 3 [0 to ± 999.999in] or [0 to ± 9999.99mm]

This value is added to the current measurement (or position) when: Pr 30 ≠ 0, and **3** is displayed in the upper left area of the LCD.

Default Value = 3 in. (76.2mm)

Pr34 – Offset 4 [0 to ± 999.999in] or [0 to ± 9999.99mm]

This value is added to the current measurement (or position) when: Pr 30 ≠ 0, and **4** is displayed in the upper left area of the LCD.

Default Value = 3 in. (76.2mm)

Pr35-Pr44

THESE FUNCTIONS DO NOT APPLY TO PROSTOP SYSTEMS

For more information: See **OPERATION, LCD READOUTS** at:
www.proscale.com/Manuals.htm

Frequently Asked Questions

What does **no Enc** mean?

If the Encoder is off the Scale, or the Encoder cable is unplugged from the Readout, **no Enc** will appear on the LCD. To clear:

1. Be sure the Encoder is on the Scale and properly oriented.
2. Unplug the Encoder from the Readout for one second and then reconnect the Encoder.
3. Connect the Encoder to the Readout.

What does **b FAIL** mean?

When the readout displays this message it means the battery voltage has dropped to a level where reliable operation is no longer possible. [Install new battery](#) to clear this message.

What does **P FAIL** mean?

When the readout displays this message it means the battery voltage has dropped to a level where reliable programming is not possible. [Install new battery](#) to clear this message.

The Readout does not change, or changes very little, as it moves.

1. The Readout is in the [HOLD](#) mode.
2. The [Scaling](#) factor is set very low.

[Additional On-Line FAQs](#)

Thank you for choosing a ProScale Product,

IT WAS PROUDLY MADE IN THE USA



Accurate Technology, Inc.

270 Rutledge Rd. Unit E

Fletcher, NC 28732 USA

828-654-7920

www.proscale.com

Please [register](#) your ProScale product.

Part # 800-1080-100 REV112012

Copyright © 2012, Accurate Technology, Inc. All rights reserved.