

Accurate

TECHNOLOGY INC.

Linear Digital Measuring Systems



Basic Readout, #700-1600-240



General Purpose Readout, #700-1600-245
(6 extra keys and more features)



General Purpose Enhanced, #700-1600-246
(firmware version ends with "C", even more features)



950 Series Readout, #700-1600-M50
(10pin input connector)

This guide applies to ProScale readouts with Firmware Version 4.02 to 4.09. (The firmware version is displayed on power-up.)

If your readout has a different firmware version, this manual should not be used. Consult factory for assistance.

**PROSCALE
FLUSH MOUNT READOUTS
QUICK-START GUIDE**

Readout serial # _____

Date of purchase _____

This Quick Start Guide is intended to help get you started using your new ProScale readout. A more comprehensive manual is available for download from www.proscale.com. Contact factory if additional information is needed.

The following programming parameters have been pre-configured at the factory for this readout. (If blank, settings are at defaults):

Parameter Pr2 (Reading Direction) _____

Parameter Pr13 (Linear Multiplier) _____

Parameter Pr14 (Compatibility) _____

If your digital scale has this pattern, set Parameter 14 to 1.



For all other scale patterns, set Parameter Pr14 to 0.

Programming menu access is disabled? _____

Readout Specifications

Display Range: Inches: ± 999.999 inches
Millimeters: ± 9999.99 mm
Centimeters: ± 999.999 cm
Fractions: $\pm 399 \frac{63}{64}$ inches

Resolution: Inches: 1, 2, 3, or 4 decimal places
Millimeters: 1 or 2 decimal places
Centimeters: 1, 2, or 3 decimal places
Fractions: $\frac{1}{16}^{\text{ths}}$, $\frac{1}{32}^{\text{nds}}$, or $\frac{1}{64}^{\text{ths}}$

Operating Power: 1 CR123 Battery, or 12-24 Volts DC

Operating Temperature: 32 to 120°F (0 to 50°C)

Installation:

These Readouts may be mounted several ways:

1. Using Velcro or double-sided tape
2. Use the 3 punch-out holes inside case.
Mount readout to machine/panel using #6 or M4 flathead screws.

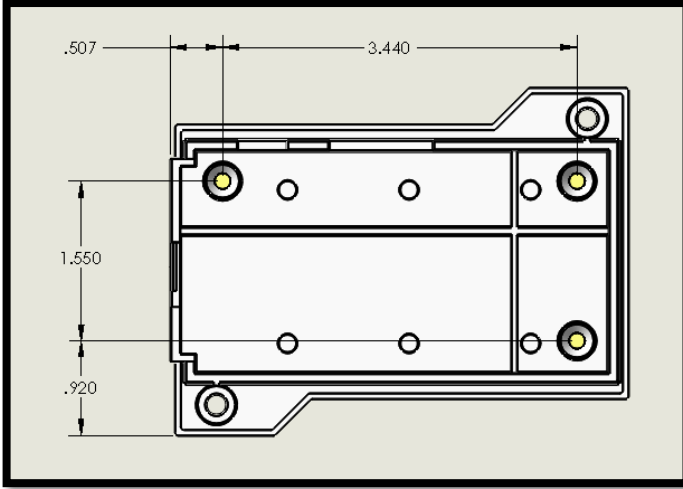

3. Use any (or all) of the six holes on the back of the readout.
Mount using 4-40 or M2 screws.

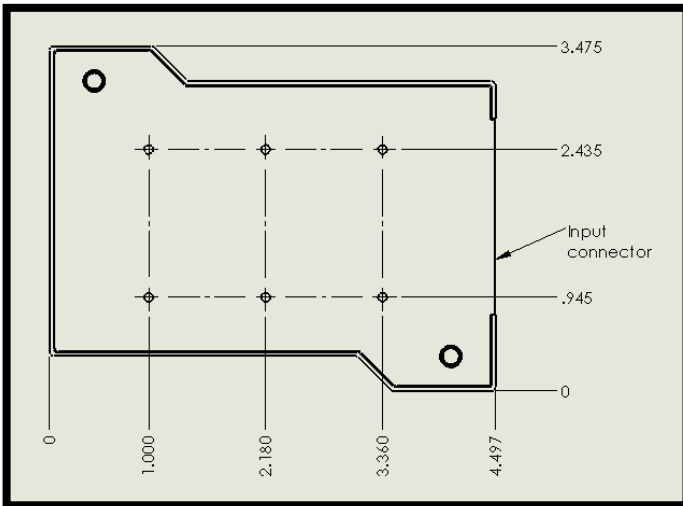

Power:

These readouts are powered by a single CR123 lithium battery. Unless specially ordered, the readout will deliver to you with the battery installed.

New for this version readout:

A battery indicator will appear on the left side of the LCD screen. There are 3 tiers of battery shown, which represent the voltage level of the battery. When only one tier is left, a new battery should be prepared for installation soon. Typical battery life for these readouts is 18 months, but life will depend on how often the readout is being used, and which programming options are enabled.



Battery Replacement:

Remove the 2 screws in the upper right and lower left corners of the readout. Lift the cover off. Remove the old battery and install a new battery, noting the proper orientation. Replace the cover and screws.

External Power:

These readouts also support use of external power if:

1. The scale type is any model **except** Model 150B or Model 250B type. (Consult factory for assistance if scale type is not known.)
2. The input power is 12 – 24 volts DC. (AC power source is not supported.)
3. The 3-position terminal strip for the readout has been supplied.
4. Common for the machine and the readout must be the same. A “hot chassis” condition may permanently damage some or all of the electronics.

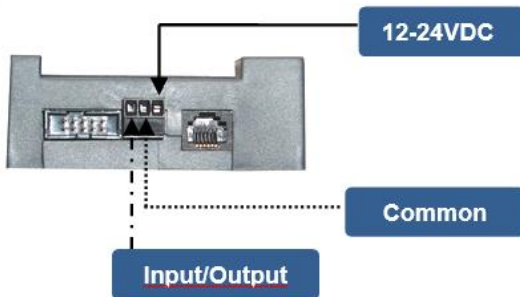

New for this version readout:

If external power is used, but a power loss occurs, the readout will automatically switch to battery power (if a battery is installed). Likewise, the readout will automatically switch to external power when it is restored.

Initial Setup:

Follow these steps to configure your readout for initial use:

1. When the readout is first powered on, it may show a **No Enc** message. This means there is not an encoder connected to the readout. To clear the message, connect a compatible encoder.
2. When an encoder is first connected, the readout may show **No Pos**. This informs the user that a position has not been programmed yet. For the initial setup, use the DATUM, and PLUS keys to set a **POSITIVE** starting value. (Any POSITIVE value will work for now.)
3. Choose the units that will be initially used (millimeters, inches, or fractions). Each press of the UNITS key will change the units that are displayed. (The screen will show the units description each time the UNITS key is pressed.)
4. Check the reading direction:
 - a) With the readout showing a POSITIVE number on the screen, move the encoder system a short distance.
 - b) Take note if the displayed value increased or decreased.
 - c) If the displayed value got larger/smaller, and this **IS** correct for your installation, no further steps are needed.
 - d) If the displayed value got larger/smaller, and this **IS NOT** correct for your installation, the reading direction needs to be reversed. This can be accomplished two ways:
 - i. If your encoder system is a Model 19, 29, 190, 290, 390, or 590 type, you can rotate the encoder 180 degrees on the scale.
 - ii. If the encoder cannot be rotated, or if the encoder is a Model 150 or Model 250 system, the reading direction must be reversed using the programming mode, parameter Pr2. Consult the Complete User Guide at www.proscale.com or contact factory for assistance with this.
5. Calibrate the readout. Since there are many thousands of applications for ProScale systems, all calibration methods cannot be described here. However, the general steps are the same.
 - a. Determine what value the readout should be showing.
 - b. Use the DATUM, PLUS, and MINUS keys to adjust the reading on the screen to match desired value. NOTE: To rapidly adjust the value, press and hold the PLUS or MINUS key down. (The update speed will increase every 2 seconds the key is held.)

Primary keys on the readout:

All the primary keys on the keypad have multiple functions.



What happens on a **QUICK PRESS** of each key?

Key	Action
ON/OFF	The readout turns on or off.
UNITS	The units change. <i>Note: Available units can be restricted with custom programming settings.</i>
PLUS	The displayed value is increased one unit.
DATUM	The displayed value is set to the pre-programmed datum value. <i>Note: This value is zero by default, but it can be custom programmed to be any value.</i>
MINUS	The displayed value is decreased one unit.

What happens if a **KEY IS HELD DOWN**?

Key	Action
ON/OFF	Nothing
UNITS	Nothing
PLUS	The displayed value increases faster each 2 seconds.
DATUM	After 4 seconds, the battery voltage is displayed. After 7 seconds, the readout's temperature is displayed.
MINUS	The displayed value decreases faster each 2 seconds.

Key COMBINATIONS:

For these actions, **press and hold the first key**, then quickly **press and release** the second key. (*This action is the same as making a capital letter on a computer; the first key acts like SHIFT.*)

Press and hold	Then quickly press and release	Action
ON/OFF	UNITS	LOCK (or unlock) the keypad.
ON/OFF	DATUM	Enters or exits the programming mode.
UNITS	PLUS	Adds one segment to displayed value. (<i>Models 150/250 only.</i>)
UNITS	MINUS	Adds one segment to displayed value. (<i>Models 150/250 only.</i>)

Supplemental keys:

Some readout models have a supplemental keypad that allows additional features to be used. See below for functions of these keys:





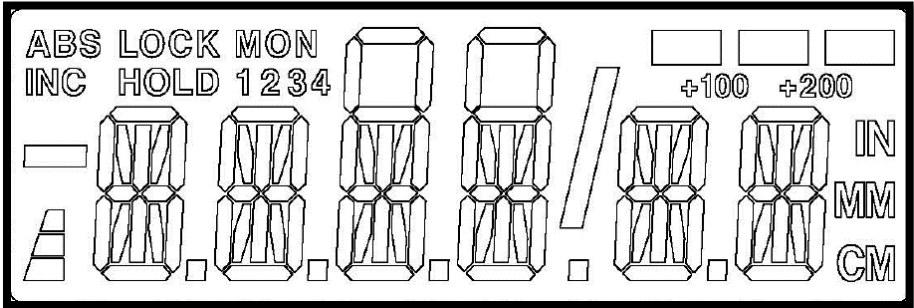

Key	Quick press action	Press and hold action
ABS/INC	When in ABS mode, no action. When in INC mode, the INC value is reset.	When in ABS mode, toggles readout to INC mode. When in INC mode, toggles readout back to ABS mode.
SEND	The currently displayed value is sent to the SPC port.	<i>None</i>
F1	An offset value is applied. <i>(If offset feature is enabled in the programming menu).</i> Also used to store compensation point data in Enhanced Readouts.	<i>None</i>
F2	Used to set compensation end point for Enhanced Readouts.	<i>None</i>
F3	Turns Monitor mode on or off. <i>(If monitor feature is enabled in the programming menu.)</i> Starts editor for Go/NoGo editor. <i>(If Go/NoGo feature is enabled.)</i>	<i>None</i>
F4	Turns HOLD mode on or off. <i>(If hold feature is enabled in the programming menu.)</i> Edits values in Go/NoGo editor. <i>(If Go/NoGo feature is enabled.)</i>	<i>None</i>

What do all the Symbols mean?:



Symbol	Meaning
ABS	The digital readout is operating in Absolute measurement mode.
INC	The digital readout is operating in Incremental (temporary) mode. Press and hold ABS/INC key 3 seconds to go back to ABS mode.
LOCK	The readout is in LOCK mode. This prevents loss of calibration if PLUS, MINUS, or DATUM keys are pressed. See page 6 for key combination to turn this off.
HOLD	The readout's display is frozen. When this feature is enabled, press F4 key to turn on/off.
MON	Monitor mode (drift alarm) is turned on. When this feature is enabled, press F3 key to turn on/off.
1 2 3 4	When any of these are displayed, the readout is adding a programmed offset value to the primary dimension. Offsets are useful for applications with multiple fixed data points.
	These are used with 16 th and 32 nd fractional inch modes. Each bar represents an extra 1/64 th long/heavy on the dimension.

Symbols (continued):

	When using fractions over 99 inches, one (or both) of these will light to show a value over 100 inches. For example: measurement is 205 5/16. The readout will show 5 5/16 and turn on the +200 indicator.
	Minus sign. Turns on when a negative value is displayed.
	Battery level indicator. When all 3 bars are lit, your battery is good. When only bottom bar is lit, a new battery is needed soon.
	Vinculum – used in fractions mode to separate numerator from denominator.
	Units indicator. IN is for INCHES or fractions. MM for millimeters. CM for centimeters. (Press UNITS key to change.)

Additional Information:

Consult the Complete User Guide at www.proscale.com or contact factory for assistance with any of these more advanced functions:

SPC PORT: Position data can be requested by external devices, or sent from readouts equipped with a SEND key.



INPUT AND OUTPUT:

Input / Output

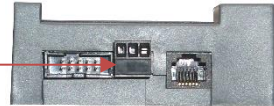

The third terminal on this strip allows for external devices (such as pushbuttons) to act as any key on the readout. Alternatively, this terminal can be used as an output control for limits, position monitor alarm, or Go/NoGo features.

SPECIAL MODES: Your readout has several special modes/features that can be enabled to add functionality. These include:

Mode/feature	Function
Offsets	Allows the readout to track up to 5 reference positions at the same time.
Monitor	Allows the readout to watch for unintended motion/drift.
Hold	Allows the readout to freeze the screen temporarily.
Go, NoGo	Allows the readout to act as a Go, NoGo gage (up to 32 positions can be stored).
Limits	Allows readout to alert operator if position moves outside a preset zone.
Input device mapping	Controls how a pushbutton or footswitch works with the readout.
Output controls	Choose how the output of the readout works.
Compensation	Linear, Temperature, and Non-Linear compensation can be used to increase accuracy.
Programming Mode	Where you customize several dozen parameters to get the readout working exactly as you need.

Note: Some of the above features are not available on every readout model.

Programming Mode:

Many features of the readout can be customized, plus additional tools can be configured using the programming menu. Consult the Complete User Guide at www.proscale.com for more information about accessing, changing, and saving customized settings.

Before making changes, open the readout case and verify the programming menu is accessible. The jumper to the left of the battery has three pins. Ensure pins 1 and 2 are connected with a shunt before proceeding. (After making changes, you can move the shunt to pins 2 and 3 to prevent further programming changes.)

To start the programming menu, turn on the readout.

1. Press and hold the UNITS key.
 2. Quickly press and release DATUM key. You will see **PG on**, then **Pr1**.
 3. Release the UNITS key.
 4. After a moment, the value for Pr1 will display.
- Change the parameter value using the PLUS or MINUS keys.
 - Default the parameter value using the DATUM key.
 - Advance to next parameter by pressing the UNITS key.
 - Exit programming menu following steps 1-3 above (OR wait 30 seconds). Note: Changes made are immediately active.

Parameter number	What it does	Default value
Pr1	Sets the value that is displayed when DATUM key is pressed.	0.000
Pr2	0 = numbers increase when encoder moves right 1 = numbers decrease when encoder moves right	0
Pr3	0 = PLUS, MINUS, and DATUM keys are operative 1 = These keys are locked out.	0
Pr4	Value controls the resolution for decimals.	3
Pr5	How much motion is needed to wake up the readout.	0.004 inches
Pr6	Controls if fractions round up or down.	0 (round down)
Pr7	Controls resolution of 4 th decimal place (in inches)	1 (.0005" resolution)
Pr11	Controls which units modes appear.	0 (All units)
Pr12	Auto-off timer (in minutes)	15





Pr13	Linear multiplier	1.00000
Pr14	Encoder compatibility	1 (Absolute scale)
Pr15	LCD contrast adjustment	27
Pr16	Final linear multiplier	1.00000
Pr22	ABS/INC key operation	0 (2 seconds)
Pr23	Supplemental keys enabled?	3 (All enabled)
Pr24	Monitor/hold, Go/NoGo features	0 (Disabled)
Pr25	Go/NoGo values to save	0 (None)
Pr26	Drift Monitor tolerance	.01 inches
Pr27	Limits modes used	0 (Not used)
Pr28	Lower limit value	0.000
Pr29	Upper limit value	5.000 inches
Pr30	Offset additions to use	0 (None)
Pr31	First offset value	0.5000 inches
Pr32	Second offset value	2.0000 inches
Pr33	Third offset value	3.0000 inches
Pr34	Fourth offset value	3.0000 inches
Pr35	External input operation mapping #1	0 (No function)
Pr36	External input operation mapping #2	0 (No function)
Pr37	Polarity for Output functions	0 (Normally open)
Pr38	Output Function used	0 (None)
Pr39 *	Turn on non-linear compensation	0 (Disabled)
Pr40 *	Non-linear correction step value	5.000 inches
Pr41 *	Temperature compensation on/off	0 (Off)
Pr44 *	Coefficient used for temperature	150

* These parameters are only included on readout #700-1600-246.

Common Error messages

Message	What it means
<i>no Enc</i>	There is not an encoder connected to the readout, or the connected encoder has a fault.
<i>no Pos</i>	The readout has not been calibrated yet.
<i>b fail</i>	The battery in the readout needs to be replaced immediately.
<i>f fail</i>	The readout cannot display fractional values larger than 399 63/64 inches.
<i>P fail</i>	The battery in the readout needs to be replaced immediately. Check programming values after new battery is installed.
<i>LOCK</i>	The keypad is LOCKed, but an attempt was made to change the calibration. Unlock keypad to fix, see page 6.
<i>P LOCK</i>	The keypad is LOCKed, but an attempt was made to change the calibration. Change Pr3 to fix, see page 11.
<i>no oFF</i>	Offsets are disabled, but an attempt was made to apply an offset value.
<i>MON flashing</i>	Monitor mode is turned on, and the system is out of the allowable position.
<i>no Co</i>	Non-linear compensation is enabled, but there is no look-up data for the displayed measurement.
<i>uL, LL</i>	Limits mode is turned on, and a limit has been exceeded.
<i>Reset</i>	The digital readout's parameters have just been defaulted.
<i>Bad pt</i>	The readout expected an entry different than it received.

Accessories

<p>External Power and I/O plug Part number 200-1016-001. Adds external power and/or input/output capabilities to the readout.</p>	 A black plastic component with several ports and a mounting bracket.
<p>Switching power supply Part number 550-2003-001. Provides 15VDC power to the readout.</p>	 A black rectangular power supply unit with a power cord and a DC output cable.
<p>Wireless Data Transmitter Part number 700-1037-001. Transmits measurement values to a remote computer, using Zigbee wireless.</p>	 A grey rectangular device with a label that reads "Accurate TECHNOLOGY INC. SPEC RF TRANSMITTER". It has several buttons and a small display.
<p>Analog Interface/converter Part number 700-1040-001. Converts measurement values to 0-5VDC (or 0-10VDC) voltage – excellent for PLC connections.</p>	 A white rectangular device with a label that reads "Accurate TECHNOLOGY INC. ProScale™ Analog Interface Unit". It has a green terminal block on top and a status indicator on the front.
<p>Bluetooth Transmitter</p>	<p>Coming July 2020</p>

Popular ProScale Products

ProStop is a complete Digital Stop and Fence System for miter and chop saws. It includes an aluminum Fence, a Flip-Stop with fine adjust, double locking mechanism, and Quick-Sets. Many add-on plates available too!



ProPanel is a GIANT DIGITAL CALIPER used to make inside, outside, diagonal, hole-edge and hole-hole dimensional measurements.

This is a rugged linear measuring tool designed to make "on the manufacturing floor" measurements.



ProKit 590 is an ideal foundation for a 'build-it-yourself' dimensional measuring system. ProKit 590 is available in measuring lengths up to 190 inches (4.8m). SPC output comes standard. Wireless data transmitter is available.



ProTable-SA is a self-contained, single axis measuring table/QC station. Leg sets and casters make this product easy to move around the manufacturing floor. Temperature compensation and non-linear error correction are built into the readout. Systems are available up to 24 ft. long. Accuracy within +/- .003 inches over the entire range. SPC output and temperature compensation are included. Custom configurations are available in one or two-axis versions.



ProTable-CAB is a two-axis measuring system designed for quick and affordable length and width measurements of cabinet doors or other panel type products. Can be built with angle and out-of-square measurements too.



Thank you for choosing a ProScale Product,

IT WAS PROUDLY MADE IN THE USA



Accurate Technology, Inc.

270 Rutledge Rd. Unit E

Fletcher, NC 28732 USA

1-828-654-7920

www.proscale.com